

**Chapter 8 SELF-TEST Phylogenetic methods**

1. The number of possible distinct unrooted trees with 5 species is

- A. 15
- B. 25
- C. 5!
- D.  $\frac{5!}{3 \times 2!}$

2. The following four trees are unrooted and branch lengths are not drawn to scale. Which statement is correct?

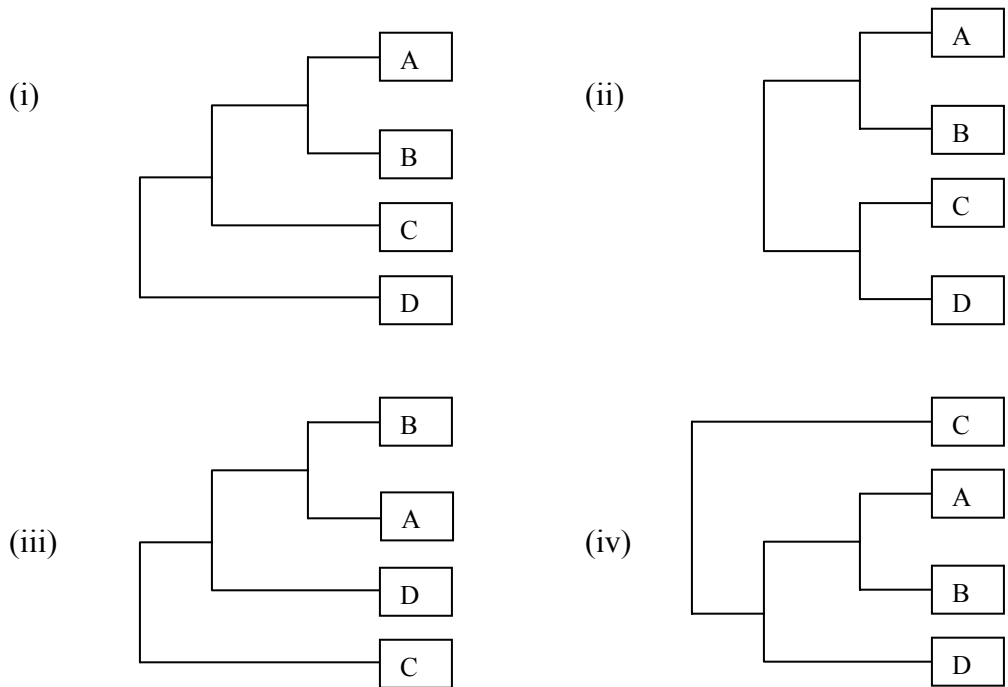

- A. All four trees are non-equivalent.
- B. All four trees are equivalent.
- C. Only trees (i) and (iii) are equivalent.
- D. Only trees (iii) and (iv) are equivalent.

3. If the same four trees are now taken to be rooted, which statement is correct?

- A. All four trees are non-equivalent.
- B. All four trees are equivalent.
- C. Only trees (i) and (iii) are equivalent.
- D. Only trees (iii) and (iv) are equivalent.

4. Which of these statements about phylogenetic methods is correct?

- A. Bootstrapping can be used as a measure of confidence of the evolutionary model used in the phylogeny.
- B. Bootstrapping cannot be done if the rate of substitution varies across sites.
- C. Transition substitutions will usually saturate at a smaller divergence time than transversion substitutions.
- D. Long branch attraction arises when the lengths of the sequences in the analysis vary a great deal.

5. The alignment below is thought to be part of a protein-coding gene. Which of the four conclusions would you draw?

Wombat	:	GT	TAA	TG	AG	TG	GT	TAT	CC	AGA	AG	TG	AG	ATA	:	30
Opossum	:	GT	TAA	TG	AG	TG	GT	TAT	TC	AGA	AG	TG	AG	ATA	:	30
Rhinoceros	:	GT	TAA	TG	AG	TG	GT	TTT	CC	AGA	AG	TG	AA	ATA	:	30
Pig	:	GT	TAA	TG	AG	TG	GT	TTT	CT	AGA	AG	CG	AA	ATA	:	30
Hedgehog	:	GT	GAA	TG	AA	TG	CG	CTT	CC	AGA	AG	TG	AA	CTG	:	30
Human	:	GT	TAA	TG	AG	TG	GT	TTT	CC	AGA	AG	TG	AA	CTG	:	30
Hare	:	GT	TAA	CG	AG	TG	GT	TCT	CC	AGA	AG	TG	AA	ATG	:	30

- A. This is probably part of a pseudogene.
- B. This is more likely to be part of an RNA-coding gene than a protein.
- C. There is evidence that transversions occur more frequently than transitions.
- D. There is evidence that synonymous substitutions occur more frequently than non-synonymous substitutions.

6. The following four phylogenetic trees have been proposed for the species in the previous sequence alignment. The standard parsimony criterion (minimization of the required number of mutations) is used to distinguish between the four trees using the above sequence data. Which conclusion would you draw?

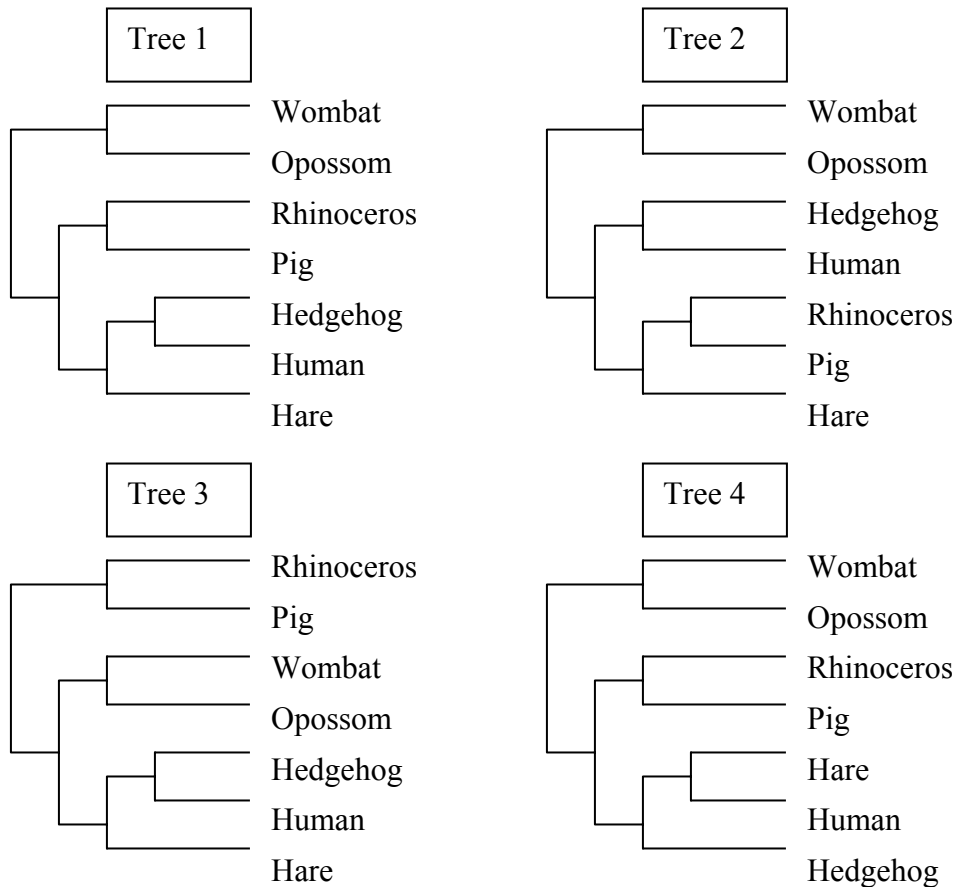

According to the parsimony criterion:

- A . Tree 1 is preferable to all other trees.
- B . Trees 1 and 2 are preferable to Trees 3 and 4.
- C . Trees 1 and 3 are preferable to Trees 2 and 4.
- D . Trees 1 and 4 are preferable to Trees 2 and 3.

7. Which of the four trees A, B, C or D corresponds to the result of the UPGMA algorithm applied to the distance matrix below? (The branch lengths are not drawn to scale).

	<i>W</i>	<i>X</i>	<i>Y</i>	<i>Z</i>
<i>W</i>	–	0.3	0.4	0.5
<i>X</i>	0.3	–	0.5	0.5
<i>Y</i>	0.4	0.5	–	0.4
<i>Z</i>	0.5	0.5	0.4	–

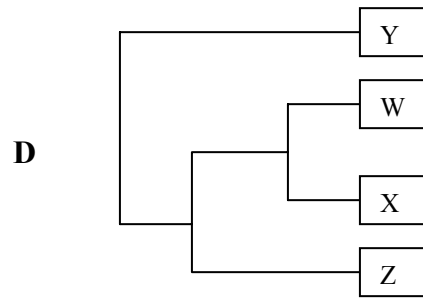
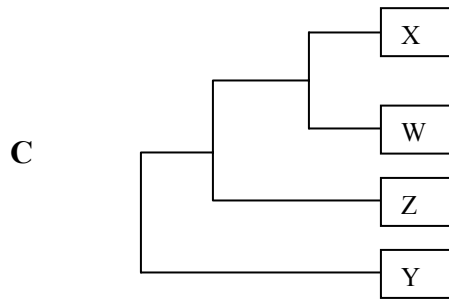
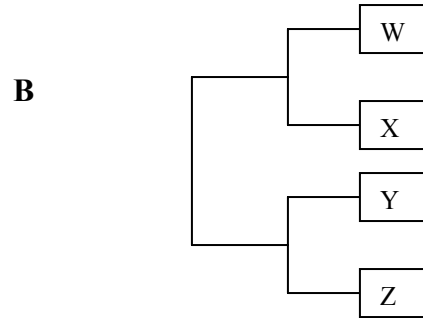
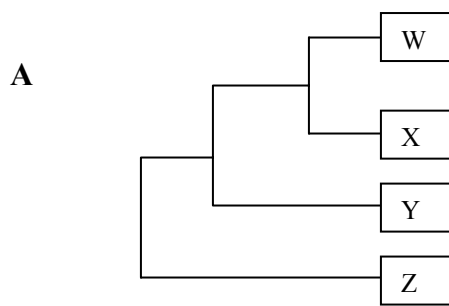

8. 100 bootstrap data-sets are created for a set of sequences. The Neighbour-Joining method is applied to these data-sets to give 100 trees. The consensus tree of this set of 100 trees is given below with bootstrap percentages indicated. It has been rooted by assuming that U is the outgroup. Which of the four conclusions can be drawn?

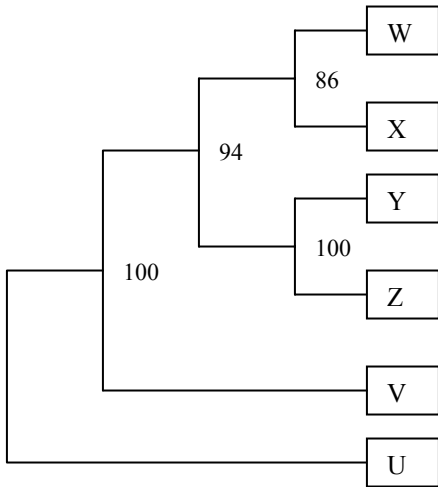

- A. The clade X+Y+Z never occurs in the set of 100 trees.
- B. The clade W+X+V never occurs in the set of 100 trees.
- C. The clade W+X+V could occur in up to 6 of the 100 trees.
- D. The clade W+V could occur in up to 14 of the 100 trees.

9. Which of the following statements about phylogenetic methods is correct?

- A. The Maximum Likelihood method determines the tree for which the likelihood of the tree given the data is largest.
- B. The Maximum Likelihood tree may sometimes contain branches of zero length.
- C. If the trees from Maximum Likelihood, Parsimony and Neighbour-Joining methods all have the same topology, this must be the correct topology.
- D. In Bayesian phylogenetic methods, if the prior probabilities of two trees are equal, then the posterior probabilities must also be equal.