

Smith's Elements of Soil Mechanics

Eighth Edition

Ian Smith
Napier University, Edinburgh

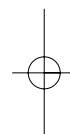
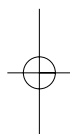

Blackwell
Publishing

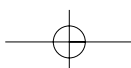

© Ian Smith 2006

© G. N. Smith 1968, 1971, 1974, 1978, 1982, 1990, 1998

Blackwell Science Ltd, a Blackwell Publishing Company

Editorial Offices:

9600 Garsington Road, Oxford OX4 2DQ

Tel: +44 (0)1865 776868

Blackwell Science, Inc., 350 Main Street
Malden, MA 02148-5018, USA

Tel: +1 781 388 8250

Iowa State Press, a Blackwell Publishing Company, 2121 State Avenue, Ames, Iowa
50014-8300, USA

Tel: +1 515 292 0140

Blackwell Science Asia Pty, 54 University Street,
Carlton, Victoria 3053, Australia

Tel: +61 (0)3 9347 0300

Blackwell Wissenschafts Verlag,
Kurfürstendamm 57, 10707 Berlin, Germany

Tel: +49 (0)30 32 79 060

The right of the Author to be identified as the Author of this Work has been asserted in accordance with the Copyright, Designs and Patents Act 1988.

All rights reserved. No part of this publication may be reproduced, stored in a retrieval system, or transmitted, in any form or by any means, electronic, mechanical, photocopying, recording or otherwise, except as permitted by the UK Copyright, Designs and Patents Act 1988, without prior permission of the publisher.

First published by Crosby Lockwood & Son Ltd 1968

Second edition 1971

Third edition published by Crosby Lockwood

Staples 1974

Reprinted 1975

Fourth edition 1978

Reprinted in paperback 1978

Reprinted by Granada Publishing 1979, 1981

Fifth edition 1982

Reprinted 1983, 1984

Reprinted by Collins Professional and Technical Books 1987

Sixth edition published by BSP Professional Books 1990

Reprinted by Blackwell Science 1990, 1992, 1993, 1994, 1995

Seventh edition published by Blackwell Science 1998

Reprinted 2000, 2003

Eighth edition published by Blackwell Publishing 2006

ISBN10: 1-4051-3370-8

ISBN13: 978-1-4051-3370-1

A catalogue record for this title is available from the British Library

Set in 10/12 pt Times
by Graphicraft Limited, Hong Kong
Printed and bound in Great Britain
by TJ International Ltd, Padstow, Cornwall

For further information on
Blackwell Publishing, visit our website:
www.blackwellpublishing.com

Contents

<i>Preface</i>	viii
<i>Notation Index</i>	x
1 Classification and Identification Properties of Soil	1
1.1 Agricultural and engineering soil	1
1.2 Engineering definitions	2
1.3 Clays	4
1.4 Soil classification	6
1.5 Common types of soil	15
1.6 Soil classification and description	16
1.7 Soil properties	23
1.8 Soil physical relations	33
Exercises	34
2 Soil Water, Permeability and Flow	37
2.1 Subsurface water	37
2.2 Flow of water through soils	39
2.3 Darcy's law of saturated flow	40
2.4 Coefficient of permeability (k)	40
2.5 Determination of k in the laboratory	41
2.6 Determination of k in the field	45
2.7 Approximation of k	48
2.8 General differential equation of flow	48
2.9 Potential and stream functions	50
2.10 Flow nets	52
2.11 Hydraulic gradient	52
2.12 Calculation of seepage quantities from a flow net	54
2.13 Drawing a flow net	55
2.14 Critical hydraulic gradient, i_c	57
2.15 Seepage forces	58
2.16 Alleviation of piping	58
2.17 Design of filters	59
2.18 Total and effective stress	63
2.19 Capillarity	64
2.20 Earth dams	67
2.21 The problem of stratification	73
2.22 Calculation of seepage quantities in an anisotropic soil	75
2.23 Permeability of sedimentary deposits	78

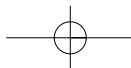

2.24	Seepage through soils of different permeability	81
2.25	Refraction of flow lines at interfaces	82
	Exercises	84
3	Shear Strength of Soils	87
3.1	Friction	87
3.2	Complex stress	88
3.3	The Mohr circle diagram	89
3.4	Cohesion	93
3.5	Coulomb's law of soil shear strength	94
3.6	Modified Coulomb's law	95
3.7	The Mohr–Coulomb yield theory	96
3.8	Determination of the shear strength parameters	97
3.9	Determination of the total stress parameters ϕ_u and c_u	105
3.10	Determination of the effective stress parameters ϕ' and c'	107
3.11	The pore pressure coefficients A and B	111
3.12	The triaxial extension test	116
3.13	Behaviour of soils under shear	120
3.14	Variation of the pore pressure coefficient A	124
3.15	Operative strengths of soils	125
3.16	Space diagonal and octahedral plane	127
3.17	Sensitivity of clays	132
3.18	Activity of a clay	133
3.19	Residual strength of soil	135
	Exercises	138
4	Elements of Stress Analysis	143
4.1	Stress–strain relationships	143
4.2	The state of stress at a point within a soil mass	144
4.3	Stresses induced by the self-weight of the soil	145
4.4	Stresses induced by applied loads	146
4.5	Influence charts for vertical stress increments	151
4.6	Bulbs of pressure	152
4.7	Shear stresses	153
4.8	Contact pressure	155
	Exercises	157
5	Stability of Slopes	159
5.1	Granular materials	159
5.2	Soils with two strength components	162
5.3	Methods of investigating slope stability	163
5.4	Total stress analysis	163
5.5	Effective stress analysis	176
5.6	Planar failure surfaces	192
5.7	Slope stability analysis to Eurocode 7	196
	Exercises	200

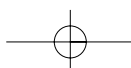
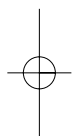

6	Lateral Earth Pressure	211
6.1	Introduction	211
6.2	Active and passive earth pressure	211
6.3	Active pressure in cohesionless soils	213
6.4	Surcharges	220
6.5	The effect of cohesion on active pressure	227
6.6	Choice of method for prediction of active pressure	236
6.7	Design parameters for different soil types	237
6.8	The choice of backfill material	239
6.9	Earth pressure at rest	245
6.10	Influence of wall yield on design	246
6.11	Strutted excavations	247
6.12	Passive pressure in cohesionless soils	248
6.13	The effect of cohesion on passive pressure	251
6.14	Operative values for ϕ and c for passive pressure	253
	Exercises	255
7	Earth Retaining Structures	257
7.1	Main types of earth retaining structures	257
7.2	Gravity walls	257
7.3	Embedded walls	260
7.4	Design of earth retaining structures	262
	7.4.1 Design to BS 8002: 1994	262
	7.4.2 Geotechnical design to Eurocode 7	263
7.5	Design of gravity walls	269
7.6	Design of sheet pile walls	282
7.7	Reinforced soil	297
7.8	Soil nailing	299
	Exercises	300
8	Bearing Capacity of Soils	303
8.1	Bearing capacity terms	303
8.2	Types of foundation	303
8.3	Analytical methods for the determination of the ultimate bearing capacity of a foundation	304
8.4	Determination of the safe bearing capacity	313
8.5	The effect of groundwater on bearing capacity	314
8.6	Developments in bearing capacity equations	314
8.7	Designing spread foundations to Eurocode 7	320
8.8	Non-homogeneous soil conditions	327
8.9	<i>In situ</i> testing for ultimate bearing capacity	330
8.10	Pile foundations	337
8.11	Designing pile foundations to Eurocode 7	350
8.12	Pile groups	356
	Exercises	358

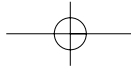

9	Foundation Settlement and Soil Compression	361
9.1	Settlement of a foundation	361
9.2	Immediate settlement	362
9.3	Consolidation settlement	373
9.4	Two-dimensional stress paths	394
	Exercises	401
10	Rate of Foundation Settlement	403
10.1	Analogy of consolidation settlement	403
10.2	Distribution of the initial excess pore pressure, u_i	403
10.3	Terzaghi's theory of consolidation	404
10.4	Average degree of consolidation	408
10.5	Drainage path length	409
10.6	Determination of the coefficient of consolidation, c_v , from the consolidation test	410
10.7	Determination of the permeability coefficient from the consolidation test	412
10.8	Determination of the consolidation coefficient from the triaxial test	412
10.9	The model law of consolidation	414
10.10	Consolidation during construction	416
10.11	Consolidation by drainage in two and three dimensions	419
10.12	Numerical determination of consolidation rates	420
10.13	Construction pore pressures in an earth dam	426
10.14	Numerical solutions for two- and three-dimensional consolidation	428
10.15	Sand drains	431
	Exercises	437
11	Compaction and Soil Mechanics Aspects of Highway Design	439
11.1	Laboratory compaction of soils	439
11.2	Main types of compaction plant	447
11.3	Moisture content value for <i>in situ</i> compaction	449
11.4	Specification of the field compacted density	450
11.5	<i>In situ</i> tests carried out during earthwork construction	452
11.6	Highway design	455
	Exercises	470
12	Unsaturated Soils	473
12.1	Unsaturated soils	473
12.2	Measurement of soil suction	475
12.3	Soil structure changes with water content	477
12.4	Stress states in unsaturated soils	479
13	Critical State Theory	483
13.1	Critical state theory	483
13.2	Symbols	483

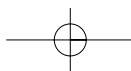
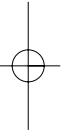
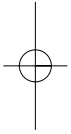

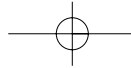

13.3	Critical state	484
13.4	Isotropic consolidation	485
13.5	Stress paths in three-dimensional stress space	487
13.6	The critical state line	489
13.7	Representation of triaxial tests in p' - q - v space	492
13.8	The Roscoe surface	495
13.9	The overall state boundary	498
13.10	Equation of the Hvorslev surface	499
13.11	Residual and critical strength states	501
14	Site Investigation and Ground Improvement	503
14.1	Desk study	503
14.2	Site reconnaissance	504
14.3	Ground investigation	505
14.4	Site investigation reports	513
14.5	Ground improvement	516
14.6	Environmental geotechnics	520
	<i>References</i>	521
	<i>Index</i>	531

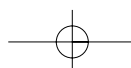
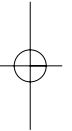
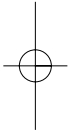

Preface

It took a whole quarter of a century to get there, but at last, in December 2004, the long-awaited *Eurocode 7: Geotechnical design – Part 1: General rules* was finally published. This European design standard is to be fully adopted by 2010 and its introduction and subsequent implementation mean a radical change to all aspects of geotechnical design across Europe. This affects practising engineers, university lecturers of geotechnical engineering and, of course, all students undertaking courses in civil engineering. The long-established, traditional approaches to geotechnical design must now be moved to one side to make way for the new limit state design approach advocated in Eurocode 7. This is a daunting thought for lecturers and students alike and so I have endeavoured to make the understanding of the new Code as simple and painless as possible by introducing it in this, the eighth edition of *Elements of Soil Mechanics*. Through several worked examples and clear explanatory text, the philosophy of Eurocode 7 and its design approaches are set out covering a whole range of topics including slope stability, retaining walls and shallow and deep foundations.

To help the reader follow many of the principles and worked examples in the book, I have produced a suite of spreadsheets and portable documents to accompany the book. The spreadsheets match up against many of the worked examples and these can be used by the reader to better understand the analysis being adopted in the worked example. This, I hope, will be particularly beneficial to understanding the Eurocode 7 design examples. In addition, I have produced the solutions to the exercises at the end of the chapters as a series of portable document format (pdf) files. All of these files can be freely downloaded from: <http://sbe.napier.ac.uk/esm>.

Whilst the introduction of Eurocode 7 has driven the bulk of the new material in this edition, I have also updated other aspects of the text throughout. This was done in recognition that some aspects of the book had become dated as a result of the introduction of new methods and standards. Furthermore, the format of the book has been improved to aid readability and thus help the reader in understanding the material. All in all, I believe I have produced a valuable and very up-to-date textbook on soil mechanics from which the learning of the subject should be made easier.

I must thank Dr Andrew Bond, Director of Geocentrix and UK delegate on the Eurocode 7 committee, for his feedback during the preparation of the material for the chapters dealing with Eurocode 7. Also, thanks must go to my colleague Dr John McDougall for his advice on the revisions I have made to the chapter on unsaturated soils.



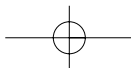

G. N. Smith, 1927–2002

In April 2002 my father died. This edition of the book would not have been written had it not been for the popularity of the earlier editions that he wrote, and I am grateful that I had the opportunity to write this edition based on his previous accomplishment. This edition is as much his work as mine.

Ian Smith
October 2005

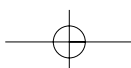
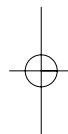
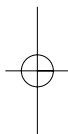

Notation Index

The following is a list of the more important symbols used in the text.

A	Area, pore pressure coefficient
A'	Effective foundation area
A_b	Area of base of pile
A_r	Area ratio
A_s	Area of surface of embedded length of pile shaft
B	Width, diameter, pore pressure coefficient
B'	Effective foundation width
C	Cohesive force, constant
C_C	Compression index, soil compressibility
C_r	Static cone resistance
C_s	Constant of compressibility
C_u	Uniformity coefficient
C_v	Void fluid compressibility
D	Diameter, depth factor, embedded length of pile
D_r	Relative density
D_{10}	Effective particle size
E	Modulus of elasticity, efficiency of pile group
E_d	Eurocode 7 design value of effect of actions
$E_{dst;d}$	Eurocode 7 design value of effect of destabilising actions
$E_{stb;d}$	Eurocode 7 design value of effect of stabilising actions
F	Factor of safety
F_b	Factor of safety on pile base resistance
$F_{c;d}$	Eurocode 7 design axial compression load on a pile
F_d	Eurocode 7 design value of an action
F_{rep}	Eurocode 7 representative value of an action
F_s	Factor of safety on pile shaft resistance
$G_{dst;d}$	Eurocode 7 design value of destabilising permanent vertical action (uplift)
G_s	Particle specific gravity
$G_{stb;d}$	Eurocode 7 design value of stabilising permanent vertical action (uplift)
$G'_{stb;d}$	Eurocode 7 design value of stabilising permanent vertical action (heave)
GWL	Groundwater level
H	Thickness, height, horizontal load
I	Index, moment of inertia
I_L	Liquidity index
I_p	Plasticity index
I_σ	Vertical stress influence factor

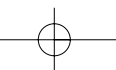

K	Factor, ratio of σ_3/σ_1
K_a	Coefficient of active earth pressure
K_0	Coefficient of earth pressure at rest
K_p	Coefficient of passive earth pressure
K_s	Pile constant
L	Length
L'	Effective foundation length
M	Moment, slope projection of critical state line, mass, mobilisation factor
M_s	Mass of solids
M_w	Mass of water
MCV	Moisture condition value
N	Number, stability number, specific volume for $\ln p' = 0$ (one-dimensional consolidation), uncorrected blow count in SPT
N'	Corrected blow count in SPT
N_c, N_q, N_γ	Bearing capacity coefficients
P	Force
P_a	Thrust due to active earth pressure
P_p	Thrust due to passive earth pressure
P_w	Thrust due to water or seepage forces
Q	Total quantity of flow in time t
Q_b	Ultimate soil strength at pile base
Q_s	Ultimate soil strength around pile shaft
Q_u	Ultimate load carrying capacity of pile
R	Radius, reaction, residual factor
$R_{b;cal}$	Eurocode 7 calculated value of pile base resistance
$R_{b;k}$	Eurocode 7 characteristic value of pile base resistance
R_c	Eurocode 7 compressive resistance of ground against a pile at ultimate limit state
$R_{c;cal}$	Eurocode 7 calculated value of R_c
$R_{c;d}$	Eurocode 7 design value of R_c
$R_{c;k}$	Eurocode 7 characteristic value of R_c
$R_{c;m}$	Eurocode 7 measured value of R_c
R_d	Eurocode 7 design resisting force
R_o	Overconsolidation ratio (one-dimensional)
R_p	Overconsolidation ratio (isotropic)
$R_{s;cal}$	Eurocode 7 calculated value of pile shaft resistance
$R_{s;k}$	Eurocode 7 characteristic value of pile shaft resistance
S	Vane shear strength
$S_{dst;d}$	Eurocode 7 design value of destabilising seepage force
S_r	Degree of saturation
S_t	Sensitivity
T	Time factor, tangential force, surface tension, torque
T_d	Eurocode 7 design value of total shearing resistance around structure
U	Average degree of consolidation
U_z	Degree of consolidation at a point at depth z
V	Volume, vertical load

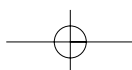
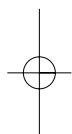

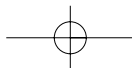

V_a	Volume of air
$V_{dst;d}$	Eurocode 7 design value of destabilising vertical action on a structure
V_s	Volume of solids
V_v	Volume of voids
V_w	Volume of water
W	Weight
W_s	Weight of solids
W_w	Weight of water
X_d	Eurocode 7 design value of a material property
X_k	Eurocode 7 representative value of a material property
Z	Section modulus
a	Area, intercept of MCV calibration line with w axis
b	Width, slope of MCV calibration line
c	Unit cohesion with respect to total stresses
c'	Unit cohesion with respect to effective stresses
c_b	Undisturbed soil shear strength at pile base
c'_d	Eurocode 7 design value of effective cohesion
c_r	Residual value of cohesion
c_u	Undrained unit cohesion
\bar{c}_u	Average undrained shear strength of soil
$c_{u;d}$	Eurocode 7 design value of undrained shear strength
c_v	Coefficient of consolidation
c_w	Unit cohesion between wall and soil
d	Pile penetration, pile diameter
d_c, d_q, d_γ	Depth factors
e	Void ratio, eccentricity
f_s	Ultimate skin friction for piles
g	Gravitational acceleration
h	Hydrostatic head, height
h_c	Capillary rise, tension crack depth
h_e	Equivalent height of soil
h_w	Excess head
i	Hydraulic gradient
i_c	Critical hydraulic gradient
i_c, i_q, i_γ	Inclination factors
k	Coefficient of permeability
l	Length
m	Stability coefficient
m_B, m_L	Eurocode 7 load inclination factor parameters
m_v	Coefficient of volume compressibility
n	Porosity, stability coefficient
p	Pressure, mean pressure
p_a	Active earth pressure
p_c	Preconsolidation pressure (one-dimensional)
p'_e	Equivalent consolidation pressure (isotropic)

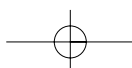

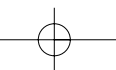

p_0	Earth pressure at rest
p'_m	Preconsolidation pressure (isotropic)
p'_o	Effective overburden pressure
p_p	Passive earth pressure
q	Unit quantity of flow, deviator stress, uniform surcharge
q_a	Safe bearing capacity
q_u	Ultimate bearing capacity
$q_{u\ net}$	Net ultimate bearing capacity
r	Radius, radial distance, finite difference constant
r_u	Pore pressure ratio
s	Suction value of soil, stress parameter
s_c, s_q, s_γ	Shape factors
s_w	Corrected drawdown in pumping well
t	Time, stress parameter
u, u_w	Pore water pressure
u_a	Pore air pressure, pore pressure due to σ_3 in a saturated soil
u_d	Pore pressure due to $(\sigma_1 - \sigma_3)$ in a saturated soil
$u_{dst;d}$	Eurocode 7 design value of destabilising total pore water pressure
u_i	Initial pore water pressure
v	Velocity, specific volume
w	Water, or moisture, content
w_L	Liquid limit
w_P	Plastic limit
w_s	Shrinkage limit
x	Horizontal distance
y	Vertical, or horizontal, distance
z	Vertical distance, depth
z_o	Depth of tension crack
α	Angle, pile adhesion factor
β	Slope angle
Γ	Eurocode 7 over-design factor, specific volume at $\ln P' = 0$
γ	Unit weight (weight density)
γ'	Submerged, buoyant or effective unit weight (effective weight density)
$\gamma_{A;dst}$	Eurocode 7 partial factor: accidental action – unfavourable
γ_b	Bulk unit weight (bulk weight density), Eurocode 7 partial factor: pile base resistance
γ'_c	Eurocode 7 partial factor: effective cohesion
γ_{cu}	Eurocode 7 partial factor: undrained shear strength
γ_d	Dry unit weight (dry weight density)
γ_F	Eurocode 7 partial factor for an action
$\gamma_{G;dst}$	Eurocode 7 partial factor: permanent action – unfavourable
$\gamma_{G;stb}$	Eurocode 7 partial factor: permanent action – favourable
γ_M	Eurocode 7 partial factor for a soil parameter
$\gamma_{Q;dst}$	Eurocode 7 partial factor: variable action – unfavourable
γ_{qu}	Eurocode 7 partial factor: unconfined compressive strength

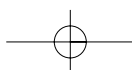
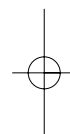

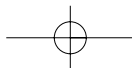

γ_R	Eurocode 7 partial factor for a resistance
γ_{Re}	Eurocode 7 partial factor: earth resistance
γ_{Rh}	Eurocode 7 partial factor: sliding resistance
γ_{Rv}	Eurocode 7 partial factor: bearing resistance
γ_s	Eurocode 7 partial factor: pile shaft resistance
γ_{sat}	Saturated unit weight (saturated weight density)
γ_t	Eurocode 7 partial factor: pile total resistance
γ_w	Unit weight of water (weight density of water)
γ_γ	Eurocode 7 partial factor: weight density
γ_ϕ'	Eurocode 7 partial factor: angle of shearing resistance
δ	Ground–structure interface friction angle
ε	Strain
θ	Angle subtended at centre of slip circle
κ	Slope of swelling line
λ	Slope of normal consolidation line
μ	Settlement coefficient, one micron, Poisson's ratio
ξ_1, ξ_2	Eurocode 7 correlation factors to evaluate results of static pile load tests
ξ_3, ξ_4	Eurocode 7 correlation factors to derive pile resistance from ground investigation results
ρ	Density, settlement
ρ'	Submerged, buoyant or effective density
ρ_b	Bulk density
ρ_c	Consolidation settlement
ρ_d	Dry density
ρ_i	Immediate settlement
ρ_{sat}	Saturated density
ρ_w	Density of water
σ	Total normal stress
σ'	Effective normal stress
σ_a, σ'_a	Total, effective axial stress
σ'_e	Equivalent consolidation pressure (one-dimensional)
σ_{oct}	Octahedral normal stress
σ_r, σ'_r	Total, effective radial stress
$\sigma_{stb;d}$	Eurocode 7 design value of stabilising total vertical stress
σ'_v	Effective overburden pressure
$\bar{\sigma}'_v$	Average effective overburden pressure
$\sigma_1, \sigma_2, \sigma_3$	Total major, intermediate and minor stress
$\sigma'_1, \sigma'_2, \sigma'_3$	Effective major, intermediate and minor stress
τ	Shear stress
τ_{oct}	Octahedral shear stress
ϕ	Angle of shearing resistance with respect to total stresses
ϕ'	Angle of shearing resistance with respect to effective stresses
$\phi_{cv;d}$	Design value of critical state angle of shearing resistance
ϕ'_d	Design value of ϕ'
χ	Saturation parameter
ψ	Angle of back of wall to horizontal

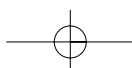

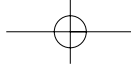

Chapter 8

Bearing Capacity of Soils

8.1 Bearing capacity terms

The following terms are used in bearing capacity problems.

Ultimate bearing capacity

The value of the average contact pressure between the foundation and the soil which will produce shear failure in the soil.

Safe bearing capacity

The maximum value of contact pressure to which the soil can be subjected without risk of shear failure. This is based solely on the strength of the soil and is simply the ultimate bearing capacity divided by a suitable factor of safety.

Allowable bearing pressure

The maximum allowable net loading intensity on the soil allowing for both shear and settlement effects.

8.2 Types of foundation

Strip foundation

Often termed a *continuous footing* this foundation has a length significantly greater than its width. It is generally used to support a series of columns or a wall.

Pad footing

Generally an individual foundation designed to carry a single column load although there are occasions when a pad foundation supports two or more columns.

Raft foundation

This is a generic term for all types of foundations that cover large areas. A raft foundation is also called a *mat foundation* and can vary from a fascine mattress supporting a farm road to a large reinforced concrete basement supporting a high rise block.

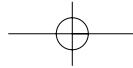

Pile foundation

Piles are used to transfer structural loads to either the foundation soil or the bedrock underlying the site. They are usually designed to work in groups, with the column loads they support transferred into them via a capping slab.

Pier foundation

This is a large column built up either from the bedrock or from a slab supported by piles. Its purpose is to support a large load, such as that from a bridge. A pier operates in the same manner as a pile but it is essentially a short squat column whereas a pile is relatively longer and more slender.

Shallow foundation

A foundation whose depth below the surface, z , is equal to or less than its least dimension, B . Most strip and pad footings fall into this category.

Deep foundation

A foundation whose depth below the surface is greater than its least dimension. Piles and piers fall into this category.

8.3 Analytical methods for the determination of the ultimate bearing capacity of a foundation

The ultimate bearing capacity of a foundation is given the symbol q_u and there are various analytical methods by which it can be evaluated. As will be seen, some of these approaches are not all that suitable but they still form a very useful introduction to the study of the bearing capacity of a foundation.

8.3.1 *Earth pressure theory*

Consider an element of soil under a foundation (Fig. 8.1). The vertical downward pressure of the footing, q_u , is a major principal stress causing a corresponding Rankine

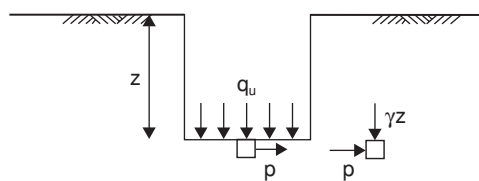
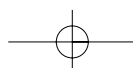

Fig. 8.1 Earth pressure conditions immediately below a foundation.



active pressure, p . For particles beyond the edge of the foundation this lateral stress can be considered as a major principal stress (i.e. passive resistance) with its corresponding vertical minor principal stress γz (the weight of the soil).

Now

$$p = q_u \frac{1 - \sin \phi}{1 + \sin \phi}$$

also

$$p = \gamma z \frac{1 + \sin \phi}{1 - \sin \phi}$$

$$\Rightarrow q_u = \gamma z \left(\frac{1 + \sin \phi}{1 - \sin \phi} \right)^2$$

This is the formula for the ultimate bearing capacity, q_u . It will be seen that it is not satisfactory for shallow footings because when $z = 0$ then, according to the formula, q_u also = 0.

Bell's development of the Rankine solution for c - ϕ soils gives the following equation:

$$q_u = \gamma z \left(\frac{1 + \sin \phi}{1 - \sin \phi} \right)^2 + 2c \sqrt{\left(\frac{1 + \sin \phi}{1 - \sin \phi} \right)^3} + 2c \sqrt{\frac{1 + \sin \phi}{1 - \sin \phi}}$$

For $\phi = 0^\circ$,

$$q_u = \gamma z + 4c$$

or $q_u = 4c$ for a surface footing.

8.3.2 Slip circle methods

With slip circle methods the foundation is assumed to fail by rotation about some slip surface, usually taken as the arc of a circle. Almost all foundation failures exhibit rotational effects, and Fellenius (1927) showed that the centre of rotation is slightly above the base of the foundation and to one side of it. He found that in a saturated cohesive soil the ultimate bearing capacity for a surface footing is

$$q_u = 5.52c_u$$

To illustrate the method we will consider a foundation failing by rotation about one edge and founded at a depth z below the surface of a saturated clay of unit weight γ and undrained strength c_u (Fig. 8.2).

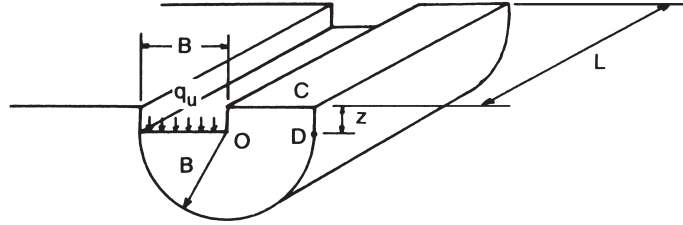
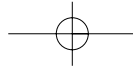

Fig. 8.2 Foundation failure rotation about one edge.

Disturbing moment about O:

$$q_u \times LB \times \frac{B}{2} = \frac{q_u LB^2}{2} \quad (1)$$

Resisting moments about O

$$\begin{aligned} \text{Cohesion along cylindrical sliding surface} &= c_u \pi LB \\ \Rightarrow \text{Moment} &= \pi c_u LB^2 \end{aligned} \quad (2)$$

$$\begin{aligned} \text{Cohesion along CD} &= c_u zL \\ \Rightarrow \text{Moment} &= c_u zLB \end{aligned} \quad (3)$$

Weight of soil above foundation level = γzLB

$$\Rightarrow \text{Moment} = \frac{\gamma zLB^2}{2} \quad (4)$$

For limit equilibrium (1) = (2) + (3) + (4)

i.e.

$$\begin{aligned} \frac{q_u LB^2}{2} &= \pi c_u LB^2 + c_u zLB + \frac{\gamma zLB^2}{2} \\ \Rightarrow q_u &= 2\pi c_u + \frac{2c_u z}{B} + \gamma z \\ &= 2\pi c_u \left(1 + \frac{1}{\pi} \frac{z}{B} + \frac{1}{2\pi} \frac{\gamma z}{c_u} \right) \\ &= 6.28c_u \left(1 + 0.32 \frac{z}{B} + 0.16 \frac{\gamma z}{c_u} \right) \end{aligned}$$

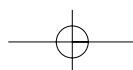

Cohesion of end sectors

The above formula only applies to a strip footing, and if the foundation is of finite dimensions then the effect of the ends must be included.

To obtain this it is assumed that when the cohesion along the perimeter of the sector has reached its maximum value, c_u , the value of cohesion at some point on the sector at distance r from O is $c_r = c_u r/B$, as shown in Fig. 8.3.

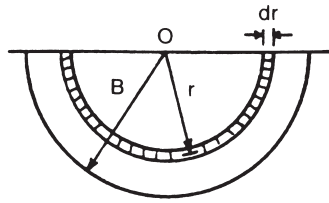

Fig. 8.3 Cohesion of end sectors.

Rotational resistance of an elemental ring, dr thick

$$= \frac{c_u r}{B} \times \pi r dr$$

$$\text{Moment about } O = \frac{c_u r}{B} \times \pi r dr \times r = \pi \frac{c_u}{B} r^3 dr$$

$$\begin{aligned} \text{Total moment of both ends} &= 2 \int_0^B \pi \frac{c_u}{B} r^3 dr \\ &= 2\pi \frac{c_u}{B} \times \frac{B^4}{4} = \frac{\pi c_u B^3}{2} \end{aligned} \quad (5)$$

This analysis ignores the cohesion of the soil above the base of the foundation at the two ends, but unless the foundation is very deep this will have little effect on the value of q_u . The term (5) should be added into the original equation.

For a surface footing the formula for q_u is:

$$q_u = 6.28c_u$$

This value is high because the centre of rotation is actually above the base, but in practice a series of rotational centres are chosen and each circle is analysed (as for a slope stability problem) until the lowest q_u value has been obtained. The method can be extended to allow for frictional effects but is considered most satisfactory when used for cohesive soils; it was extended by Wilson (1941), who prepared a chart (Fig. 8.4) which gives the centre of the most critical circle for cohesive soils (his technique is not applicable to other categories of soil or to surface footings).

The slip circle method is useful when the soil properties beneath the foundation vary, since an approximate position of the critical circle can be obtained from

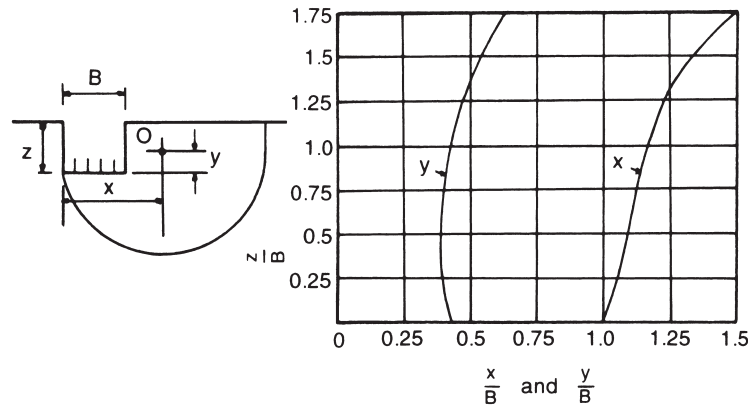
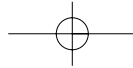

Fig. 8.4 Location of centre of critical circle for use with Fellenius' method (after Wilson, 1941).

Fig. 8.4 and then other circles near to it can be analysed. When the soil conditions are uniform Wilson's critical circle gives

$$q_u = 5.52c_u$$

for a surface footing.

8.3.3 Plastic failure theory

Forms of bearing capacity failure

Terzaghi (1943) stated that the bearing capacity failure of a foundation is caused by either a general soil shear failure or a local soil shear failure. Vesic (1963) listed punching shear failure as a further form of bearing capacity failure.

(1) General shear failure

The form of this failure is illustrated in Fig. 8.5, which shows a strip footing. The failure pattern is clearly defined and it can be seen that definite failure surfaces develop within the soil. A wedge of compressed soil (I) goes down with the footing, creating slip surfaces and areas of plastic flow (II). These areas are initially prevented from moving outwards by the passive resistance of the soil wedges (III). Once this passive resistance is overcome, movement takes place and bulging of the soil surface around the foundation occurs. With general shear failure collapse is sudden and is accompanied by a tilting of the foundation.

(2) Local shear failure

The failure pattern developed is of the same form as for general shear failure but only the slip surfaces immediately below the foundation are well defined. Shear failure is local and does not create the large zones of plastic failure which develop with

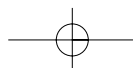

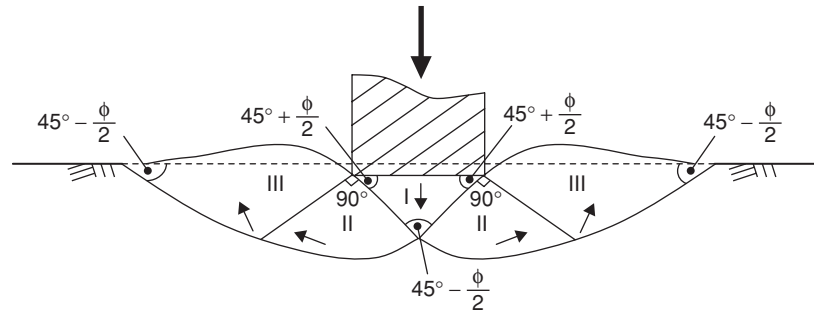

Fig. 8.5 General shear failure.

general shear failure. Some heaving of the soil around the foundation may occur but the actual slip surfaces do not penetrate the surface of the soil and there is no tilting of the foundation.

(3) Punching shear failure

This is a downward movement of the foundation caused by soil shear failure only occurring along the boundaries of the wedge of soil immediately below the foundation. There is little bulging of the surface of the soil and no slip surfaces can be seen.

For both punching and local shear failure, settlement considerations are invariably more critical than those of bearing capacity so that the evaluation of the ultimate bearing capacity of a foundation is usually obtained from an analysis of general shear failure.

Prandtl's analysis

Prandtl (1921) was interested in the plastic failure of metals and one of his solutions (for the penetration of a punch into metal) can be applied to the case of a foundation penetrating downwards into a soil with no attendant rotation.

The analysis gives solutions for various values of ϕ , and for a surface footing with $\phi = 0$, Prandtl obtained:

$$q_u = 5.14c$$

Terzaghi's analysis

Working on similar lines to Prandtl's analysis, Terzaghi (1943) produced a formula for q_u which allows for the effects of cohesion and friction between the base of the footing and the soil and is also applicable to shallow ($z/B \leq 1$) and surface foundations. His solution for a strip footing is:

$$q_u = cN_c + \gamma zN_q + 0.5\gamma BN_\gamma \tag{6}$$

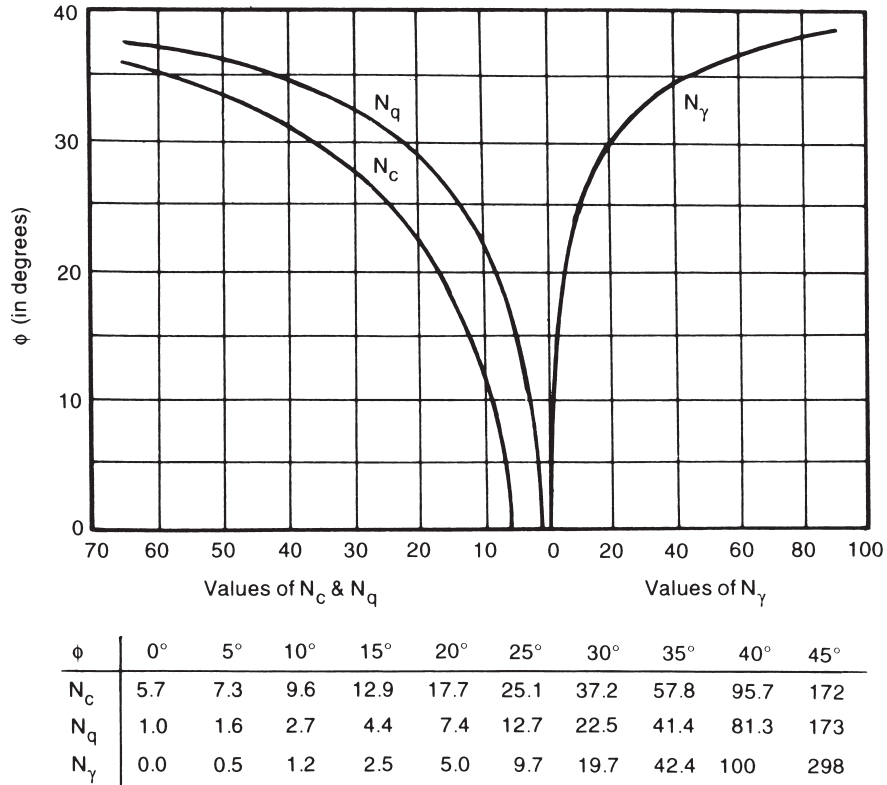

Fig. 8.6 Terzaghi's bearing capacity coefficients.

The coefficients N_c , N_q and N_γ depend upon the soil's angle of shearing resistance and can be obtained from Fig. 8.6. When $\phi = 0^\circ$, $N_c = 5.7$; $N_q = 1.0$; $N_\gamma = 0$.

$$\Rightarrow q_u = 5.7c + \gamma z$$

or $q_u = 5.7c$ for a surface footing.

The increase in the value of N_c from 5.14 to 5.7 is due to the fact that Terzaghi allowed for frictional effects between the foundation and its supporting soil.

The coefficient N_q allows for the surcharge effects due to the soil above the foundation level, and N_γ allows for the size of the footing, B . The effect of N_γ is of little consequence with clays, where the angle of shearing resistance is usually assumed to be the undrained value, ϕ_u , and assumed equal to 0° , but it can become significant with wide foundations supported on cohesionless soil.

Terzaghi's solution for a circular footing is:

$$q_u = 1.3cN_c + \gamma zN_q + 0.3\gamma BN_\gamma \quad (\text{where } B = \text{diameter}) \quad (7)$$

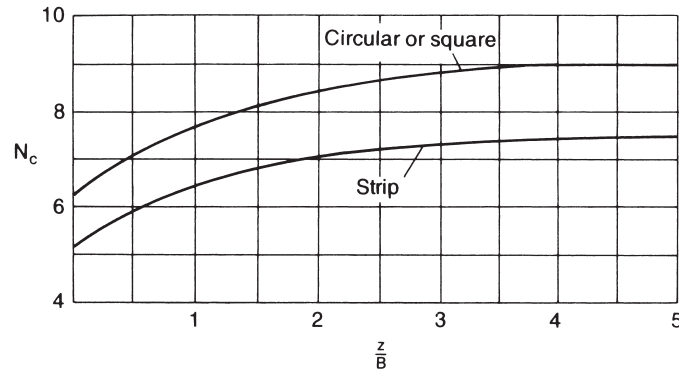

Fig. 8.7 Variation of the coefficient N_c with depth (after Skempton, 1951).

For a square footing:

$$q_u = 1.3cN_c + \gamma zN_q + 0.4\gamma BN_\gamma \quad (8)$$

and for a rectangular footing:

$$q_u = cN_c \left(1 + 0.3 \frac{B}{L} \right) + \gamma zN_q + 0.5\gamma BN_\gamma \left(1 - 0.2 \frac{B}{L} \right) \quad (9)$$

Skempton (1951) showed that for a cohesive soil ($\phi = 0^\circ$) the value of the coefficient N_c increases with the value of the foundation depth, z . His suggested values for N_c , applicable to circular, square and strip footings, are given in Fig. 8.7. In the case of a rectangular footing on a cohesive soil a value for N_c can either be estimated from Fig. 8.7 or obtained from the formula:

$$N_c = 5 \left(1 + 0.2 \frac{B}{L} \right) \left(1 + 0.2 \frac{z}{B} \right)$$

with a limiting value for N_c of $N_c = 7.5(1 + 0.2B/L)$, which corresponds to a z/B ratio greater than 2.5 (Skempton, 1951).

8.3.4 Summary of bearing capacity formula

It can be seen that Rankine's theory does not give satisfactory results and that, for variable subsoil conditions, the slip surface analysis of Fellenius provides the best solution. For normal soil conditions, Equations (6)–(9) can generally be used and may be applied to foundations at any depth in $c-\phi$ soils and to shallow foundations in cohesive soils. For deep footings in cohesive soil the values of N_c suggested by Skempton may be used in place of the Terzaghi values.

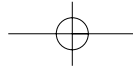

8.3.5 Choice of soil parameters

As with earth pressure equations, bearing capacity equations can be used with either the undrained or the drained soil parameters. As granular soils operate in the drained state at all stages during and after construction, the relevant soil strength parameter is ϕ' .

Saturated cohesive soils operate in the undrained state during and immediately after construction and the relevant parameters are c_u and ϕ_u (with ϕ_u generally assumed equal to zero). If required, the long-term stability can be checked with the assumption that the soil will be drained and the relevant parameters are c' and ϕ' (with c' generally taken as equal to zero) but this procedure is not often carried out.

Example 8.1

A rectangular foundation, 2 m \times 4 m, is to be founded at a depth of 1 m below the surface of a deep stratum of soft saturated clay (unit weight = 20 kN/m³).

Undrained and consolidated undrained triaxial tests established the following soil parameters: $\phi_u = 0^\circ$, $c_u = 24$ kPa; $\phi' = 25^\circ$, $c' = 0$.

Determine the ultimate bearing capacity of the foundation, (i) immediately after construction and, (ii) some years after construction.

Solution

(i) It may be assumed that immediately after construction the clay will be in an undrained state. The relevant soil parameters are therefore $\phi_u = 0^\circ$ and $c_u = 24$ kPa.

From Fig. 8.6: $N_c = 5.7$, $N_q = 1.0$, $N_\gamma = 0.0$.

$$\begin{aligned} q_u &= cN_c(1 + 0.3B/L) + \gamma zN_q \\ &= 24 \times 5.7(1 + 0.3 \times 2/4) + 20 \times 1 \times 1 \\ &= 177.3 \text{ kPa} \end{aligned}$$

(ii) It can be assumed that, after some years, the clay will be fully drained so that the relevant soil parameters are $\phi' = 25^\circ$ and $c' = 0$.

From Fig. 8.6: $N_c = 25.1$, $N_q = 12.7$, $N_\gamma = 9.7$.

$$\begin{aligned} q_u &= \gamma zN_q + 0.5\gamma BN_\gamma(1 - 0.2B/L) \\ &= 20 \times 1 \times 12.7 + 0.5 \times 20 \times 2 \times 9.7(1 - 0.2 \times 2/4) \\ &= 428.6 \text{ kPa} \end{aligned}$$

Example 8.2

A continuous foundation is 1.5 m wide and is founded at a depth of 1.5 m in a deep layer of sand of unit weight 18.5 kN/m³.

Determine the ultimate bearing capacity of the foundation if the soil strength parameters are $c' = 0$ and $\phi' =$ (i) 35° , (ii) 30° .

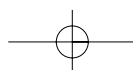

Solution

(i) From Fig. 8.6: for $\phi' = 35^\circ$, $N_c = 57.8$, $N_q = 41.4$, $N_\gamma = 42.4$. For a continuous footing:

$$\begin{aligned} q_u &= cN_c + \gamma zN_q + 0.5\gamma BN_\gamma \\ &= 18.5 \times 1.5 \times 41.4 + 0.5 \times 18.5 \times 1.5 \times 42.4 \\ &= 1737 \text{ kPa} \end{aligned}$$

(ii) From Fig. 8.6: for $\phi' = 30^\circ$, $N_c = 37.2$, $N_q = 22.5$, $N_\gamma = 19.7$.

$$\begin{aligned} q_u &= 18.5 \times 1.5 \times 22.5 + 0.5 \times 18.5 \times 1.5 \times 19.7 \\ &= 898 \text{ kPa} \end{aligned}$$

The ultimate bearing capacity is reduced by some 48 per cent when the value of ϕ' is reduced by some 15 per cent.

8.4 Determination of the safe bearing capacity

Lumped factor of safety approach

The value of the safe bearing capacity is simply the value of the net ultimate bearing capacity divided by a suitable factor of safety, F . The value of F is usually not less than 3.0, except for a relatively unimportant structure, and sometimes can be as much as 5.0. At first glance these values for F appear high but the necessity for them is illustrated in Example 8.2, which demonstrates the effect on q_u of a small variation in the value of ϕ .

The net ultimate bearing capacity is the increase in vertical pressure, above that of the original overburden pressure, that the soil can just carry before shear failure occurs.

The original overburden pressure is γz and this term should be subtracted from the bearing capacity equations, i.e. for a strip footing:

$$q_{u \text{ net}} = cN_c + \gamma z(N_q - 1) + 0.5\gamma BN_\gamma$$

The safe bearing capacity is therefore the above expression divided by F plus the term γz :

$$\text{Safe bearing capacity} = \frac{cN_c + \gamma z(N_q - 1) + 0.5\gamma BN_\gamma}{F} + \gamma z$$

In the case of a footing founded in undrained clay, where $\phi_u = 0^\circ$, the net ultimate bearing capacity is, of course, $c_u N_c$.

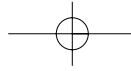

The safe bearing capacity notion is not used during design to Eurocode 7 where, as will be demonstrated in Section 8.7, conformity of the bearing resistance limit state is achieved by ensuring that the design effect of the actions does not exceed the design bearing resistance.

8.5 The effect of groundwater on bearing capacity

Water table below the foundation level

If the water table is at a depth of not less than B below the foundation, the expression for net ultimate bearing capacity is the one given above, but when the water table rises to a depth of less than B below the foundation the expression becomes:

$$q_{u\text{net}} = cN_c + \gamma z(N_q - 1) + 0.5\gamma'BN_\gamma$$

where

γ = unit weight of soil above groundwater level

γ' = effective unit weight.

For cohesive soils ϕ_u is small and the term $0.5\gamma'BN_\gamma$ is of little account, the value of the bearing capacity being virtually unaffected by groundwater. With sands, however, the term cN_c is zero and the term $0.5\gamma'BN_\gamma$ is about one half of $0.5\gamma BN_\gamma$, so that groundwater has a significant effect.

Water table above the foundation level

For this case Terzaghi's expressions are best written in the form:

$$q_{u\text{net}} = cN_c + \sigma'_v(N_q - 1) + 0.5\gamma'BN_\gamma$$

where σ'_v = effective overburden pressure removed.

From the expression it will be seen that, in these circumstances, the bearing capacity of a cohesive soil can be affected by groundwater.

8.6 Developments in bearing capacity equations

Terzaghi's bearing capacity equations have been successfully used in the design of numerous shallow foundations throughout the world and are still in use. However, they are viewed by many to be conservative as they do not consider factors that affect bearing capacity such as inclined loading, foundation depth and the shear resistance of the soil above the foundation. This section describes developments that have been made to the original equations.

8.6.1 General form of the bearing capacity equation

Meyerhof (1963) proposed the following general equation for q_u :

$$q_u = cN_c s_c i_c d_c + \gamma z N_q s_q i_q d_q + 0.5 \gamma B N_\gamma s_\gamma i_\gamma d_\gamma \quad (10)$$

where

s_c, s_q and s_γ are shape factors
 i_c, i_q and i_γ are inclination factors
 d_c, d_q and d_γ are depth factors.

Other factors, G_c, G_q and G_γ to allow for a sloping ground surface, and B_c, B_q and B_γ to allow for any inclination of the base, can also be included when required.

It must be noted that the values of N_c, N_q and N_γ used in the general bearing capacity equation are not the Terzaghi values. The values of N_c and N_q are now obtained from Meyerhof's equations (1963), as they are recognised as probably being the most satisfactory.

$$N_c = (N_q - 1) \cot \phi, \quad N_q = \tan^2 \left(45^\circ + \frac{\phi}{2} \right) e^{\pi \tan \phi}$$

Unfortunately there is not the same agreement about the remaining factor N_γ and the following expressions all have their supporters:

$$\begin{aligned} N_\gamma &= (N_q - 1) \tan 1.4\phi && \text{Meyerhof (1963)} \\ N_\gamma &= 1.5(N_q - 1) \tan \phi && \text{Hansen (1970)} \\ N_\gamma &= 2(N_q + 1) \tan \phi && \text{Vesic (1973)} \end{aligned}$$

It should be noted that Hansen suggested that the operating value of ϕ should be that corresponding to plane strain, which is some 10 per cent greater than the value of ϕ obtained from the triaxial test and normally used. With this approach Hansen's expression for $N_\gamma = 1.5(N_q - 1) \tan 1.1\phi$, which applies to a continuous footing but is probably not so relevant to other shapes of footings.

In order to give the reader some guidance it can be said that the expression suggested by Vesic is being increasingly used. Further examples in this chapter will therefore use the following expressions for the bearing capacity coefficients:

$$\begin{aligned} N_c &= (N_q - 1) \cot \phi \\ N_q &= \tan^2 \left(45^\circ + \frac{\phi}{2} \right) e^{\pi \tan \phi} \\ N_\gamma &= 2(N_q + 1) \tan \phi \end{aligned}$$

Typical values are shown in Table 8.1.

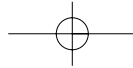
**Table 8.1** Bearing capacity factors in common use.

ϕ (°)	N_c	N_q	N_γ
0	5.14	1.00	0.00
5	6.49	1.57	0.45
10	8.34	2.47	1.22
15	10.98	3.94	2.65
20	14.83	6.40	5.39
25	20.72	10.66	10.88
30	30.14	18.40	22.40
35	46.12	33.30	48.03
40	75.31	64.20	109.41
45	133.87	134.87	271.75
50	266.88	319.06	762.86

8.6.2 Shape factors

These factors are intended to allow for the effect of the shape of the foundation on its bearing capacity. The factors have largely been evaluated from laboratory tests and the values in present use are those proposed by De Beer (1970):

$$s_c = 1 + \frac{B}{L} \cdot \frac{N_q}{N_c}$$

$$s_q = 1 + \frac{B}{L} \tan \phi$$

$$s_\gamma = 1 - 0.4 \frac{B}{L}$$

8.6.3 Depth factors

These factors are intended to allow for the shear strength of the soil above the foundation. Hansen (1970) proposed the following values:

	$z/B \leq 1.0$	$z/B > 1.0$
d_c	$1 + 0.4(z/B)$	$1 + 0.4 \arctan(z/B)$
d_q	$1 + 2 \tan \phi (1 - \sin \phi)^2 (z/B)$	$1 + 2 \tan \phi (1 - \sin \phi)^2 \arctan(z/B)$
d_γ	1.0	1.0

Note The arctan values must be expressed in radians, e.g. if $z = 1.5$ and $B = 1.0$ m then $\arctan(z/B) = \arctan(1.5) = 56.3^\circ = 0.983$ radians.

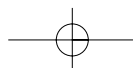

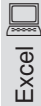
**Example 8.3**

Recalculate Example 8.1 using Meyerhof's general bearing capacity formula.

Solution

(i) From Table 8.1, for $\phi_u = 0^\circ$, $N_c = 5.14$, $N_q = 1.0$ and $N_\gamma = 0.0$.

Shape factors:

$$s_c = 1 + (2/4)(1.0/5.14) = 1.1$$

$$s_q = 1 + (2/4) \tan 0^\circ = 1.0$$

$$s_\gamma = 1 - 0.4(2/4) = 0.8$$

Depth factors:

$z/B = 1/2 = 0.5$. Using Hansen's values for $z/B \leq 1.0$:

$$d_c = 1 + 0.4(1/2) = 1.2, \quad d_q = 1.0 \text{ (as } \phi_u = 0^\circ\text{)}, \quad d_\gamma = 1.0$$

$$\begin{aligned} q_u &= cN_c s_c d_c + \gamma z N_q s_q d_q \\ &= 24 \times 5.14 \times 1.1 \times 1.2 + 20 \times 1.0 \times 1.0 \times 1.0 \\ &= 182.8 \text{ kPa} \end{aligned}$$

(ii) From Table 8.1, for $\phi' = 25^\circ$, $N_q = 10.66$ and $N_\gamma = 10.88$.

The expressions for s_q and d_q involve ϕ . These two factors will therefore have different values from those in case (i):

$$s_q = 1 + (2/4) \tan 25^\circ = 1.23$$

$$d_q = 1 + 2 \tan 25^\circ (1 - \sin 25^\circ)^2 (1/2) = 1.16$$

$$\begin{aligned} q_u &= \gamma z N_q s_q d_q + 0.5 \gamma B N_\gamma s_\gamma d_\gamma \\ &= 20 \times 1 \times 10.66 \times 1.23 \times 1.16 + 0.5 \times 20 \times 2 \times 10.88 \times 0.8 \times 1.0 \\ &= 478.3 \text{ kPa} \end{aligned}$$

**Example 8.4**

Using a factor of safety = 3.0 determine the values of safe bearing capacity for cases (i) and (ii) in Example 8.3.

Solution

Case (i):

$$q_{u \text{ net}} = q_u - \gamma z = 162.8 \text{ kPa}$$

$$\begin{aligned} \text{Safe bearing capacity} &= \frac{162.8}{3} + 20 \times 1 \\ &= 74.3 \text{ kPa} \end{aligned}$$

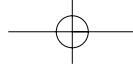

For case (ii):

$$q_{u \text{ net}} = \gamma z(N_q s_q d_q - 1) + 0.5\gamma B N_\gamma s_\gamma d_\gamma$$

$$= 458.3 \text{ kPa}$$

$$\text{Safe bearing capacity} = \frac{458.3}{3} + 20 \times 1$$

$$= 172.8 \text{ kPa}$$

8.6.4 Effect of eccentric and inclined loading on foundations

A foundation can be subjected to eccentric loads and/or to inclined loads, eccentric or concentric.

Eccentric loads

Let us consider first the relatively simple case of a vertical load acting on a rectangular foundation of width B and length L such that the load has eccentricities e_B and e_L (Fig. 8.8). To solve the problem we must think in terms of the rather artificial concept of effective foundation width and length. That part of the foundation that is symmetrical about the point of application of the load is considered to be useful, or effective, and is the area of the rectangle of effective length $L' = L - 2e_L$ and of effective width $B' = B - 2e_B$.

In the case of a strip footing of width B , subjected to a line load with an eccentricity e , then $B' = B - 2e$ and the ultimate bearing capacity of the foundation is found from either equation (6) or the general equation (10) with the term B replaced by B' .

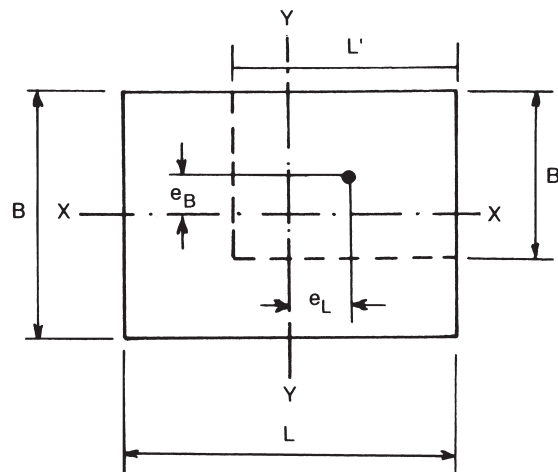
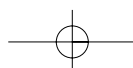

Fig. 8.8 Effective widths and area.



The overall eccentricity of the bearing pressure, e , must consider the self-weight of the foundation and is equal to:

$$e = \frac{P \times e_p}{P + W}$$

where

P = magnitude of the eccentric load
 W = self-weight of the foundation
 e_p = eccentricity of P .

Inclined loads

The usual method of dealing with an inclined line load, such as P in Fig. 8.9, is to first determine its horizontal and vertical components P_H and P_V and then, by taking moments, determine its eccentricity, e , in order that the effective width of the foundation B' can be determined from the formula $B' = B - 2e$.

The ultimate bearing capacity of the strip foundation (of width B) is then taken to be equal to that of a strip foundation of width B' subjected to a concentric load, P , inclined at α to the vertical.

Various methods of solution have been proposed for this problem, e.g. Janbu (1957), Hansen (1957), but possibly the simplest approach is that proposed by Meyerhof (1953) in which the bearing capacity coefficients N_c , N_q and N_γ are reduced by multiplying them by the factors i_c , i_q and i_γ in his general equation (10). Meyerhof's expressions for these factors are:

$$i_c = i_q = (1 - \alpha/90^\circ)^2$$

$$i_\gamma = (1 - \alpha/\phi)^2$$

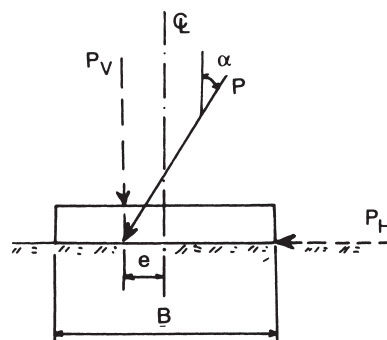
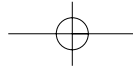

Fig. 8.9 Strip foundation with inclined load.



8.7 Designing spread foundations to Eurocode 7

The design of spread foundations is covered in Section 6 of Eurocode 7. The limit states to be checked and the partial factors to be used in the design are the same as we saw when we looked at the design of retaining walls in Section 7.4.2.

In terms of establishing the bearing resistance, the code states that a commonly recognised method should be used, and Annex D of the Standard gives a sample calculation. Interestingly the depth factors are excluded in Eurocode 7 (without explanation) and for this reason they are excluded too from the solutions to Examples 8.5 and 8.6 in this chapter. Spreadsheets *Example 8.5.xls* and *Example 8.6.xls*, however, offer the choice whether to include the depth factors or not.

While the design procedure required to satisfy the conditions of Eurocode 7 involves essentially the same methods as we have seen so far in this chapter, there are a few differences listed in Annex D which can be considered for drained conditions. These concern the shape and inclination factors as well as the bearing resistance factor, N_γ , and are listed below:

$$\begin{aligned}
 N_\gamma &= 2(N_q - 1) \tan \phi' && \text{(for a rough base, such as a typical foundation)} \\
 s_q &= 1 + (B'/L') \sin \phi' && \text{(for a rectangular foundation)} \\
 s_q &= 1 + \sin \phi' && \text{(for a square or circular foundation)} \\
 s_\gamma &= 1 - 0.3(B'/L') && \text{(for a rectangular foundation)} \\
 s_\gamma &= 0.7 && \text{(for a square or circular foundation)} \\
 s_c &= \frac{s_q N_q - 1}{N_q - 1} && \text{(rectangular, square and circle foundation)} \\
 i_c &= i_q - \left(\frac{1 - i_q}{N_c \tan \phi'} \right); && i_q = \left[1 - \frac{H}{V + A'c' \cot \phi'} \right]^m; && i_\gamma = i_q^{\left(\frac{m+1}{m}\right)}
 \end{aligned}$$

where

V = vertical load acting on foundation

H = horizontal load (or component of inclined load) acting on foundation

A' = design effective area of foundation

$$m = m_B = \frac{2 + \frac{B'}{L'}}{1 + \frac{B'}{L'}} \quad \text{when H acts in the direction of } B';$$

$$m = m_L = \frac{2 + \frac{L'}{B'}}{1 + \frac{L'}{B'}} \quad \text{when H acts in the direction of } L'.$$

Eurocode 7 also states that the vertical total action should include the weight of any backfill acting on top of the foundation in addition to the weight of the foundation itself plus the applied load it is carrying.

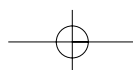

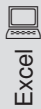

Example 8.5

A continuous footing is 1.8 m wide by 0.5 m deep and is founded at a depth of 0.75 m in a clay soil of unit weight 20 kN/m^3 with $\phi_u = 0^\circ$ and $c_u = 30 \text{ kPa}$. The foundation is to carry a vertical line load of magnitude 50 kN/m run, which will act at a distance of 0.4 m from the centre-line. Take the unit weight of concrete as 24 kN/m^3 .

- (i) Determine the safe bearing capacity for the footing, taking $F = 3.0$.
- (ii) Check the Eurocode 7 GEO limit state (Design Approach 1) by establishing the magnitude of the over-design factor.

Solution

- (i) Safe bearing capacity

Self-weight of foundation, $W_f = 0.5 \times 24 \times 1.8 = 21.6 \text{ kN/m}$ run

Weight of soil on top of foundation, $W_s = 0.25 \times 20 \times 1.8 = 9.0 \text{ kN/m}$ run

Total weight of foundation + soil, $W = 21.6 + 9.0 = 30.6 \text{ kN/m}$ run

$$\text{Eccentricity of bearing pressure, } e = \frac{P \times e_p}{P + W} = \frac{50 \times 0.4}{50 + 30.6} = 0.25 \text{ m}$$

Since $e \leq \frac{B}{6}$, the total force acts within the middle third of the foundation.

Effective width of footing, $B' = 1.8 - 2 \times 0.25 = 1.3 \text{ m}$

From Table 8.1, for $\phi_u = 0^\circ$, $N_c = 5.14$, $N_q = 1.0$, $N_\gamma = 0$.

Footing is continuous, i.e. $L \rightarrow \infty$; $s_c = 1.0$.

$$d_c = 1 + 0.4 \left(\frac{0.75}{1.8} \right) = 1.17$$

$$\begin{aligned} \text{Safe bearing capacity (per metre run)} &= \frac{q_{u \text{ net}}}{3} + \gamma z = \frac{c N_c s_c d_c}{3} + \gamma z \\ &= \frac{30 \times 5.14 \times 1.0 \times 1.17}{3} + 20 \times 0.75 \\ &= 75 \text{ kPa} \end{aligned}$$

Safe bearing capacity = $75 \times B' = 97.5 \text{ kN/m}$ run

- (ii) Eurocode 7 GEO limit state

1. Combination 1 (partial factor sets $A1 + M1 + R1$)

From Table 7.1: $\gamma_{G;\text{dst}} = 1.35$; $\gamma_{Q;\text{dst}} = 1.5$; $\gamma_{cu} = 1.0$; $\gamma_{Rv} = 1.0$.

$$\text{Design material property: } c_{u,d} = \frac{c_u}{\gamma_{cu}} = \frac{30}{1} = 30 \text{ kPa}$$

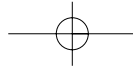

Design actions:

$$\text{Weight of foundation, } W_d = W \times \gamma_{G;dst} = 30.6 \times 1.35 = 41.3 \text{ kN/m run}$$

$$\text{Applied line load, } P_d = P \times \gamma_{G;dst} = 50 \times 1.35 = 67.5 \text{ kN/m run}$$

Effect of design actions:

$$\text{Total vertical force, } F_d = 41.3 + 67.5 = 108.8 \text{ kN/m run}$$

$$\text{Eccentricity, } e = \frac{P_d \times e_P}{P_d + W_d} = \frac{67.5 \times 0.4}{67.5 + 41.3} = 0.248 \text{ m}$$

Since $e \leq \frac{B}{6}$, the total force acts within the middle-third of the foundation.

$$\text{Effective width of footing, } B' = 1.8 - 2 \times 0.248 = 1.3 \text{ m}$$

Design resistance:

From before, $N_c = 5.14$, $N_q = 1.0$, $N_\gamma = 0$, $s_c = 1.0$.

$$\begin{aligned} \text{Ultimate bearing capacity, } q_u &= c_{u;d} N_c s_c + \gamma z N_q \\ &= 30 \times 5.14 \times 1 + 20 \times 0.75 \times 1.0 \\ &= 169.2 \text{ kPa} \end{aligned}$$

Ultimate bearing capacity per metre run, $Q_u = 169.2 \times 1.3 = 220 \text{ kN/m run}$

$$\text{Bearing resistance, } R_d = \frac{Q_u}{\gamma_{Rv}} = \frac{220}{1} = 220 \text{ kN/m run}$$

$$\text{Over-design factor, } \Gamma = \frac{R_d}{F_d} = \frac{220}{108.8} = 2.03$$

Since $\Gamma > 1$, the GEO limit state requirement is satisfied.

2. Combination 2 (partial factor sets A2 + M2 + R1)

The calculations are the same as for Combination 1 except that this time the following partial factors (from Table 7.1) are used: $\gamma_{G;dst} = 1.0$; $\gamma_{Q;dst} = 1.3$; $\gamma_{cu} = 1.40$; $\gamma_{Rv} = 1.0$.

$$c_{u;d} = 21.4 \text{ kPa}$$

$$W_d = 30.6 \times \gamma_{G;dst} = 30.6 \text{ kN/m run}$$

$$P_d = 50.0 \times \gamma_{G;dst} = 50.0 \text{ kN/m run}$$

$$F_d = 30.6 + 50.0 = 80.6 \text{ kN/m run}$$

$$e = 0.248 \text{ m; } B' = 1.3 \text{ m}$$

$$Q_u = (c_{u;d} N_c s_c + \gamma z N_q) \times B' = 125.1 \times 1.3 = 163.1 \text{ kN/m run}$$

$$R_d = \frac{Q_u}{\gamma_{Rv}} = \frac{163.1}{1} = 163.1 \text{ kN/m run}$$

$$\Gamma = \frac{R_d}{F_d} = \frac{163.1}{80.6} = 2.02$$

Since $\Gamma > 1$, the GEO limit state requirement is satisfied.

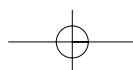

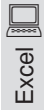
**Example 8.6**

A concrete foundation 3 m wide, 9 m long and 0.75 m deep is to be founded at a depth of 1.5 m in a deep deposit of dense sand. The angle of shearing resistance of the sand is 35° and its unit weight is 19 kN/m^3 . The unit weight of concrete is 24 kN/m^3 .

(a) Using a lumped factor of safety approach (take $F = 3.0$):

- (i) Determine the safe bearing capacity for the foundation.
- (ii) Determine the safe bearing capacity of the foundation if it is subjected to a vertical line load of 220 kN/m at an eccentricity of 0.3 m , together with a horizontal line load of 50 kN/m acting at the base of the foundation as illustrated in Figure 8.10.

(b) For the situation described in (ii) above, establish the magnitude of the over-design factor for the Eurocode 7 GEO limit state, using Design Approach 1.

Solution

(a) Lumped factor of safety

- (i) Safe bearing capacity

$$= \frac{q_{u \text{ net}}}{3} + \gamma z$$

$$= \frac{\gamma z (N_q s_q d_q - 1) + 0.5 \gamma B N_\gamma s_\gamma d_\gamma}{3} + \gamma z$$

From Table 8.1, for $\phi' = 35^\circ$, $N_q = 33.3$, $N_\gamma = 48.03$:

$$s_q = 1 + \left(\frac{3}{9}\right) \tan 35^\circ = 1.23; \quad s_\gamma = 1 - 0.4 \left(\frac{3}{9}\right) = 0.87$$

$$d_q = 1 + 2 \tan 35^\circ (1 - \sin 35^\circ)^2 \left(\frac{1.5}{3}\right) = 1.13; \quad d_\gamma = 1$$

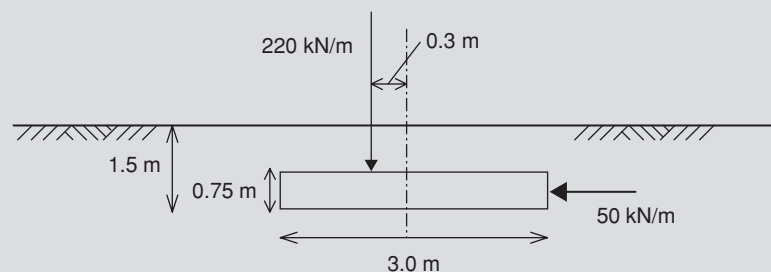
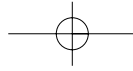

Fig. 8.10 Example 8.6.



Safe bearing capacity

$$= \frac{19 \times 1.5(33.3 \times 1.23 \times 1.13 - 1) + 0.5 \times 19 \times 3 \times 48.03 \times 0.87 \times 1.0}{3} + 19 \times 1.5$$

$$= 855.7 \text{ kPa}$$

(ii)

Self-weight of foundation, $W = 0.75 \times 9 \times 3 \times 24 = 486 \text{ kN}$

Total applied vertical load, $P = 220 \times 9 = 1980 \text{ kN}$

Total applied horizontal load, $H = 50 \times 9 = 450 \text{ kN}$

Total vertical load acting on soil, $V = 486 + 1980 = 2466 \text{ kN}$

Eccentricity of bearing pressure

$$e = \frac{P \times e_p}{P + W} = \frac{1980 \times 0.3}{2466} = 0.24 \text{ m}$$

Since $e \leq \frac{B}{6}$, the total force acts within the middle-third of the foundation.

Effective width of footing, $B' = 3.0 - 2 \times 0.24 = 2.52 \text{ m}$

The foundation is effectively acted upon by a load of magnitude, F inclined at an angle to the vertical, α :

$$F = \sqrt{V^2 + H^2} = \sqrt{2466^2 + 450^2} = 2506.7 \text{ kN}$$

$$\alpha = \tan^{-1}\left(\frac{450}{2466}\right) = 10.3^\circ$$

$$i_q = \left(1 - \frac{10.3}{90}\right)^2 = 0.78; \quad i_\gamma = \left(1 - \frac{10.3}{35}\right)^2 = 0.50$$

$$s_q = 1 + \left(\frac{2.52}{9}\right) \tan 35^\circ = 1.2; \quad s_\gamma = 1 \times 0.4 \left(\frac{2.52}{9}\right) = 0.89$$

$$d_q = 1 + 2 \tan 35^\circ (1 - \sin 35^\circ)^2 \left(\frac{1.5}{2.52}\right) = 1.15; \quad d_\gamma = 1$$

Safe bearing capacity

$$= \frac{\gamma z(N_q s_q d_q i_q - 1) + 0.5 \gamma B' N_\gamma s_\gamma d_\gamma i_\gamma}{3} + \gamma z$$

$$= \frac{19 \times 1.5(33.3 \times 1.2 \times 1.15 \times 0.78 - 1) + 0.5 \times 19 \times 2.52 \times 48.03 \times 0.89 \times 1.0 \times 0.5}{3}$$

$$+ 19 \times 1.5$$

$$= 530 \text{ kPa}$$

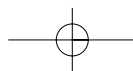

(b) Eurocode 7

Weight of soil on top of foundation, $W_s = 0.75 \times 9 \times 3 \times 19 = 384.8 \text{ kN}$

Total weight of foundation + soil, $W = 486 + 384.8 = 870.8 \text{ kN}$

1. Combination 1 (partial factor sets $AI + MI + RI$)

From Table 7.1: $\gamma_{G;dst} = 1.35$; $\gamma_{Q;dst} = 1.5$; $\gamma_{\phi'} = 1.0$; $\gamma_{Rv} = 1.0$.

Design material property: $\phi'_d = \tan^{-1} \left(\frac{\tan \phi'}{\gamma_{\phi'}} \right) = 35^\circ$

Design actions:

Weight of foundation, $W_d = W \times \gamma_{G;dst} = 870.8 \times 1.35 = 1175.6 \text{ kN}$

Applied vertical line load, $P_d = P \times \gamma_{G;dst} = 1980 \times 1.35 = 2673 \text{ kN}$

Applied horizontal line load, $H_d = H \times \gamma_{G;dst} = 450 \times 1.35 = 607.5 \text{ kN}$

Effect of design actions:

Total vertical force, $F_d = W_d + P_d = 1175.6 + 2673 = 3848.6 \text{ kN}$

Eccentricity, $e = \frac{P_d \times e_p}{P_d + W_d} = \frac{2673 \times 0.3}{3848.6} = 0.208 \text{ m}$

Since $e \leq \frac{B}{6}$, the total force acts within the middle-third of the foundation.

Effective width of footing, $B' = 3.0 - 2 \times 0.208 = 2.58 \text{ m}$

Effective area of footing, $A' = 2.58 \times 9 = 23.2 \text{ m}^2$

Design resistance:

From Table 8.1, $N_c = 46.1$, $N_q = 33.3$.

From Eurocode 7, Annex D,

$$N_\gamma = 2 (N_q - 1) \tan \phi' = 45.2$$

$$s_q = 1 + \frac{B'}{L} \sin \phi' = 1 + \left(\frac{2.58}{9} \right) \sin 35^\circ = 1.16$$

$$s_c = \frac{s_q N_q - 1}{N_q - 1} = 1.17$$

$$s_\gamma = 1 - 0.3 \left(\frac{B'}{L} \right) = 0.91$$

$$m = \frac{2 + \frac{B'}{L}}{1 + \frac{B'}{L}} = 1.78$$

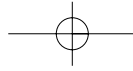

$$i_q = \left[1 - \frac{H}{V + A'c' \cot \phi'} \right]^m = \left[1 - \frac{607.5}{3848.6 + 0} \right]^{1.78} = 0.74 \quad (V = F_d)$$

$$i_c = i_q - \left(\frac{1 - i_q}{N_c \tan \phi'} \right) = 0.74 - \left(\frac{1 - 0.74}{46.1 \tan 35^\circ} \right) = 0.72$$

$$i_\gamma = i_q^{\left(\frac{m+1}{m}\right)} = 0.74^{\frac{2.78}{1.78}} = 0.62$$

Ultimate bearing capacity, per m²,

$$\begin{aligned} q_u &= c'_d N_c s_c i_c + \gamma_d z N_q s_q i_q + 0.5 B' \gamma_d N_\gamma s_\gamma i_\gamma \\ &= 0 + (19 \times 1.5 \times 33.3 \times 1.16 \times 0.74) \\ &\quad + (0.5 \times 2.58 \times 19 \times 45.2 \times 0.91 \times 0.62) \\ &= 1439 \text{ kPa} \end{aligned}$$

Ultimate bearing capacity, $Q_u = q_u \times L \times B = 1439 \times 9 \times 3 = 38\,853 \text{ kN}$

$$\text{Bearing resistance, } R_d = \frac{Q_u}{\gamma_{Rv}} = \frac{38\,853}{1} = 38\,853 \text{ kN}$$

$$\text{Over-design factor, } \Gamma = \frac{R_d}{F_d} = \frac{38\,853}{3848.6} = 10.1$$

Since $\Gamma > 1$, the GEO limit state requirement is satisfied.

2. Combination 2 (partial factor sets A2 + M2 + R1)

The calculations are the same as for Combination 1 except that this time the following partial factors (from Table 7.1) are used: $\gamma_{G;dst} = 1.0$; $\gamma_{Q;dst} = 1.3$; $\gamma_{\phi'} = 1.25$; $\gamma_{Rv} = 1.0$.

$$\phi'_d = \tan^{-1} \left(\frac{\tan \phi'}{\gamma_{\phi'}} \right) = \tan^{-1} \left(\frac{\tan 35^\circ}{1.25} \right) = 29.3^\circ$$

$$W_d = 870.8 \times \gamma_G = 870.8 \text{ kN}$$

$$P_d = 1980 \times \gamma_G = 1980 \text{ kN}$$

$$H_d = 450 \times \gamma_G = 450 \text{ kN}$$

$$e = \frac{P_d \times e_p}{P_d + W_d} = \frac{1980 \times 0.3}{1980 + 870.8} = 0.208 \text{ m} \quad (\text{within the middle-third})$$

$$B' = 3.0 - 2 \times 0.208 = 2.58 \text{ m}$$

$$N_q = 16.9, N_\gamma = 17.8, s_q = 1.14, s_\gamma = 0.91, i_q = 0.74, i_\gamma = 0.62.$$

Ultimate bearing capacity, per m²,

$$\begin{aligned} q_u &= c'_d N_c s_c i_c + \gamma z N_q s_q i_q + 0.5 B' \gamma N_\gamma s_\gamma i_\gamma \\ &= 653.5 \text{ kPa} \end{aligned}$$

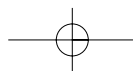

Ultimate bearing capacity, $Q_u = 653.5 \times L \times B = 17\,644 \text{ kN}$

$$\text{Bearing resistance, } R_d = \frac{Q_u}{\gamma_{Rv}} = \frac{17\,644}{1} = 17\,644 \text{ kN}$$

$$\text{Over-design factor, } \Gamma = \frac{R_d}{F_d} = \frac{17\,644}{2850.1} = 6.19$$

Since $\Gamma > 1$, the GEO limit state requirement is satisfied.

8.8 Non-homogeneous soil conditions

The bearing capacity equations (6)–(10) are based on the assumption that the foundation soil is homogeneous and isotropic.

In the case of variable soil conditions the analysis of bearing capacity can be carried out using some form of slip circle method, as described earlier in this chapter. This procedure can take time and designs based on one of the bearing capacity formulae are consequently quite often used.

For the case of a foundation resting on thin layers of soil, of thicknesses $H_1, H_2, H_3, \dots, H_n$ and of total depth H , Bowles (1982) suggests that these layers can be treated as one layer with an average c value c_{av} and an average ϕ value ϕ_{av} , where

$$c_{av} = \frac{c_1 H_1 + c_2 H_2 + c_3 H_3 + \dots + c_n H_n}{H}$$

$$\phi_{av} = \arctan \frac{H_1 \tan \phi_1 + H_2 \tan \phi_2 + H_3 \tan \phi_3 + \dots + H_n \tan \phi_n}{H}$$

Vesic (1975) suggested that, for the case of a foundation founded in a layer of soft clay which overlies a stiff clay, the ultimate bearing capacity of the foundation can be expressed as:

$$q_u = c_u N_{cm} + \gamma_z$$

where c_u = the undrained strength of the soft clay and N_{cm} = a modified form of N_c , the value of which depends upon the ratio of the c_u values of both clays, the thickness of the upper layer, the foundation depth and the shape and width of the foundation. Values of N_{cm} are quoted in Vesic's paper.

The converse situation, i.e. that of a foundation founded in a layer of stiff clay which overlies a soft clay, has been studied by Brown and Meyerhof (1969), who quoted a formula for N_{cm} based on a punching shear failure analysis.

For other cases of more heterogeneous soil conditions there is at present no recognised method by which the bearing capacity equations can be realistically applied.

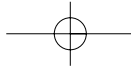

At first glance a safe way of determining the bearing capacity of a foundation might be to base it on the shear strength of the weakest soil below it, but such a procedure can be uneconomical, particularly if the weak soil is overlain by much stronger soil. A more suitable method is to calculate the safe bearing capacity using the shear strength of the stronger material and then to check the amount of overstressing that this will cause in the weaker layers. The method is shown in Example 8.7, which illustrates a typical problem that may arise during the selection of a site for a new spoil heap.

For structural foundations the factor of safety against bearing capacity failure is generally not less than 3.0, but for spoil heaps this factor can often be reduced to 2.0.

Example 8.7

The effective width of a proposed spoil heap will be about 61 m. The subsoil conditions on which the tip is to be built are shown in Fig. 8.11a.

Determine a value for the maximum safe pressure that may be exerted by the tip on to the soil.

Solution

The average undrained cohesion of the stiff clay is about 165 kPa.

Using this value with Terzaghi's formula:

$$q_u = cN_c = 165 \times 5.7 = 940 \text{ kPa}$$

$$\text{Assign safe bearing capacity} = 430 \text{ kPa}; \quad F = \frac{940}{430} = 2.19$$

Various vertical sections through the soil must now be selected (A, B, C, D and E in Fig. 8.11a). Using a contact pressure value of 430 kPa, the induced shear stresses are obtained from Fig. 4.11b, and for each section the variation in soil strength with depth is plotted along with the corresponding values of shear stress increments (Fig. 8.11b). From these plots the areas of overstressing (shown hatched) are apparent and it is possible to plot this area on a cross-section (Fig. 8.11c).

A considerable portion of the silt is overstressed and if this were applied to the design of a raft foundation carrying a normal structure it would not be acceptable. With a spoil heap, however, the amount of settlement induced would hardly be detrimental. Also, as the load will be applied gradually, there will be a chance for the silt to consolidate partially and obtain some increase in strength before the full load is applied.

Owing to the thickness of boulder clay there is little chance of a heave of the ground surface around the tip. For interest, the overstressed zone corresponding to a contact pressure of 320 kPa is also shown in Fig. 8.11c.

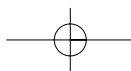

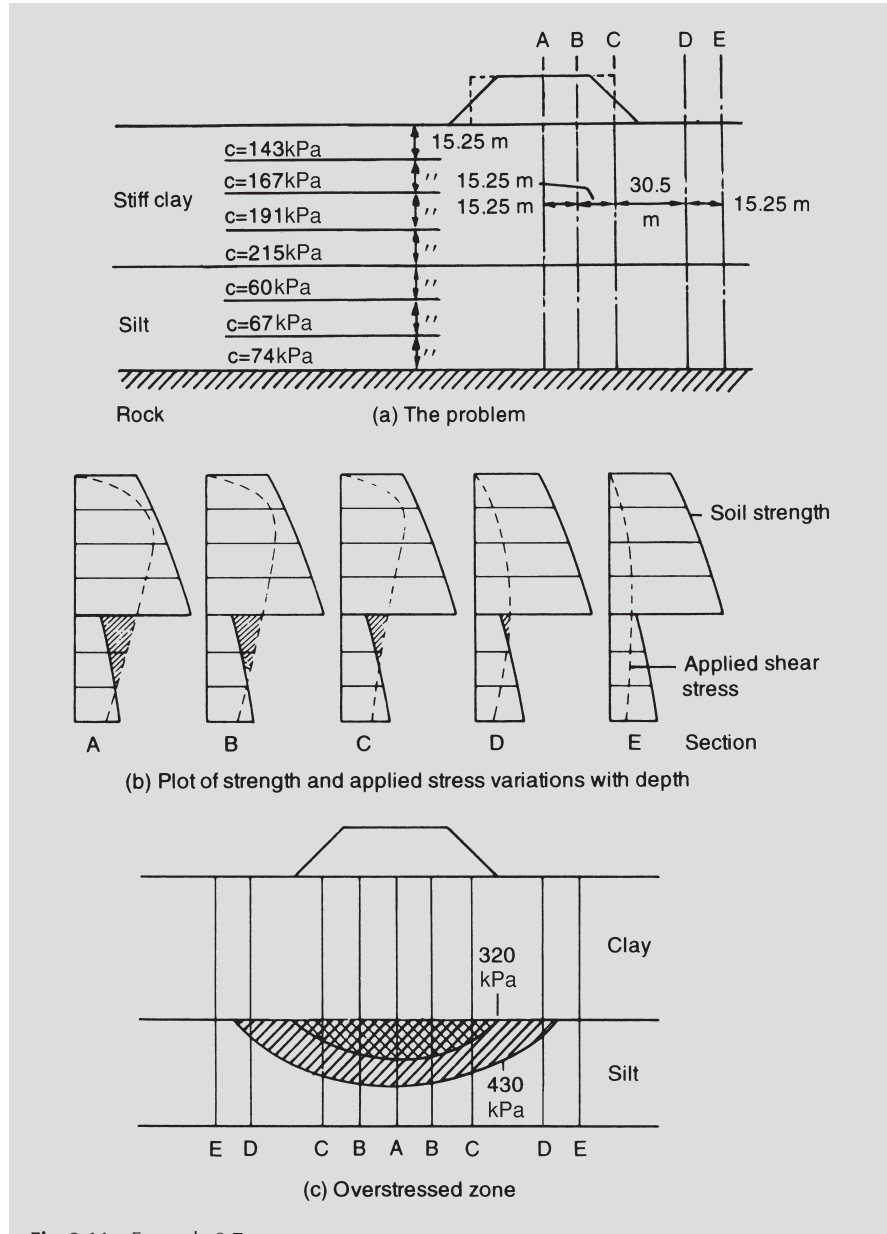
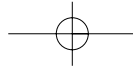

Fig. 8.11 Example 8.7.

If the contact pressure had been determined by considering the strength of the silt (average $c = 67 \text{ kPa}$):

$$q_u = 5.7 \times 67 \text{ kPa} = 382 \text{ kPa}$$

$$\text{Safe bearing capacity } (F = 2) = 191 \text{ kPa}$$



8.9 *In situ* testing for ultimate bearing capacity

8.9.1 *The plate loading test*

In this test an excavation is made to the expected foundation level of the proposed structure and a steel plate, usually from 300 to 750 mm square, is placed in position and loaded by means of a kentledge. During loading the settlement of the plate is measured and a curve similar to that illustrated in Fig. 8.12 is obtained.

On dense sands and gravels and stiff clays there is a pronounced departure from the straight line relationship that applies in the initial stages of loading, and the q_u value is then determined by extrapolating backwards (as shown in the figure). With a soft clay or a loose sand the plate experiences a more or less constant rate of settlement under load and no definite failure point can be established.

In spite of the fact that a plate loading test can only assess a metre or two of the soil layer below the test level, the method can be extremely helpful in stony soils where undisturbed sampling is not possible provided it is preceded by a boring programme, to prove that the soil does not exhibit significant variations.

The test can give erratic results in sands when there is a variation in density over the site, and several tests should be carried out to determine a sensible average. This procedure is costly, particularly if the groundwater level is near the foundation level and groundwater lowering techniques consequently become necessary.

Estimation of allowable bearing pressure from the plate loading test

As would be expected, the settlement of a square footing kept at a constant pressure increases as the size of the footing increases.

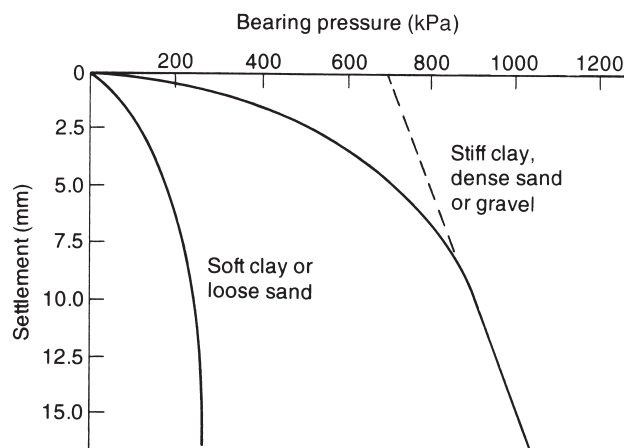
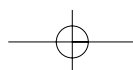

Fig. 8.12 Typical plate loading test results.



Terzaghi and Peck (1948) investigated this effect and produced the relationship:

$$S = S_1 \left(\frac{2B}{B + 0.3} \right)^2$$

where

S_1 = settlement of a loaded area 0.305 m square under a given loading intensity p

S = settlement of a square or rectangular footing of width B (in metres) under the same pressure p .

In order to use plate loading test results the designer must first decide upon an acceptable value for the maximum allowable settlement. Unless there are other conditions to be taken into account it is generally accepted that maximum allowable settlement is 25 mm.

The method for determining the allowable bearing pressure for a foundation of width B m is apparent from the formula. If S is put equal to 25 mm and the numerical value of B is inserted in the formula, S_1 will be obtained. From the plate loading test results we have the relationship between S_1 and p (Fig. 8.12), so the value of p corresponding to the calculated value of S_1 is the allowable bearing pressure of the foundation subject to any adjustment that may be necessary for certain groundwater conditions. The adjustment procedure is the same as that employed to obtain the allowable bearing pressure from the standard penetration test.

8.9.2 Standard penetration test

This test is generally used to determine the bearing capacity of sands or gravels and is conducted with a split spoon sampler (a sample tube which can be split open longitudinally after sampling) with internal and external diameters of 35 and 50 mm respectively. The sampler is sometimes referred to as the Raymond spoon sampler after the piling firm that evolved the test (Fig. 8.13). A full guide on the methods and use of the SPT is given by Clayton (1995).

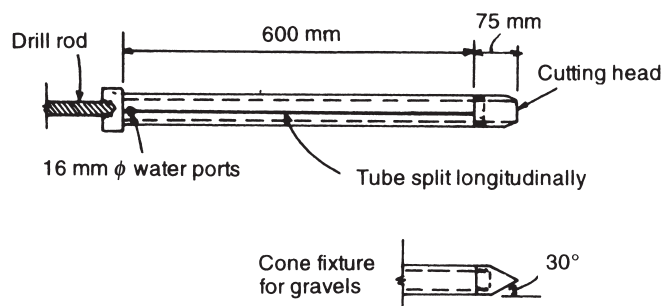
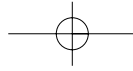

Fig. 8.13 Standard penetration test.

**Table 8.2** Relative density of sands.

N	Relative density	
	Terzaghi and Peck	Gibbs and Holtz
0–4	very loose	0–15%
4–10	loose	15–35
10–30	medium	35–65
30–50	dense	65–85
over 50	very dense	85–100

The sampler is lowered down the borehole until it rests on the layer of cohesionless soil to be tested. It is then driven into the soil for a length of 450 mm by means of a 65 kg hammer free-falling 760 mm for each blow. The number of blows required to drive the last 300 mm is recorded and this figure is designated as the N value of the soil (the first 150 mm of driving is ignored because of possible loose soil in the bottom of the borehole from the boring operations). After the tube has been removed from the borehole it can be opened and its contents examined.

In gravelly soils damage can occur to the cutting head, and a solid cone, evolved by Palmer and Stuart (1957), is fitted in its place. The N value derived from such soils appears to be of the same order as that obtained when the cutting head is used in finer soils.

Terzaghi and Peck (1948) evolved a qualitative relationship between the relative density of the soil tested and the number of blows from the standard penetration test, N. Gibbs and Holtz (1957) put figures to this relationship, which are given in Table 8.2.

Corrections to the measured N value

An important feature of the standard penetration test is the influence of the effective overburden pressure on the N count. Sand can exhibit different N values at different depths even though its relative density is constant. Terzaghi and Peck make no reference to the effects that this can have, but Gibbs and Holtz examined the effects of most of the variables involved and concluded that the significant factors affecting the N value are the relative density of the soil and the value of the effective overburden pressure removed.

Various workers have investigated this problem (Coffmann, 1960; Bazaraa, 1967), but the method proposed by Thorburn (1963) now seems to have gained general acceptance, at least in the UK.

Thorburn assumed that the original Terzaghi and Peck relationships between N and the relative density corresponded to an effective overburden pressure of 138 kPa. His correction chart therefore dealt with a range of effective overburden pressure for 0 to 138 kPa, it being tacitly assumed that for values of effective overburden pressure greater than 138 kPa, N' can be taken as equal to N.

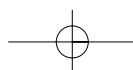

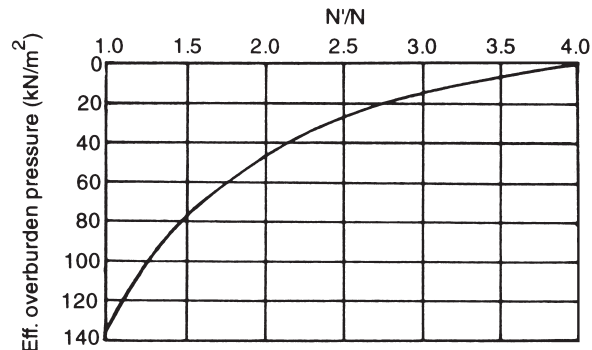

Fig. 8.14 Estimation of N' from the test value N (after Thorburn, 1963).

It is possible, by the use of Thorburn's chart, to prepare the plot of the N'/N ratio relationship to effective overburden pressure, over the range 0 to 138 kPa (roughly from 0 to 7 m depth of overburden).

This relationship is reproduced in Fig. 8.14 and can be used directly in design.

Terzaghi and Peck point out that in saturated (i.e. below the water table) fine and silty sands the N value can be altered by the low permeability of the soil. If the void ratio of the soil is higher than that corresponding to its critical density, the penetration resistance is less than in a large-grained soil of the same relative density. Conversely, if the void ratio is less than that corresponding to critical density the penetration resistance is increased.

The value of N corresponding to the critical density appears to be about 15, and Terzaghi and Peck suggest that if the number of measured blows, N , is greater than 15 it should be assumed that the density of the tested soil is equal to that of a sand for which the number of blows is equal to $15 + 0.5(N - 15)$, i.e.:

$$\text{True } N = 15 + 0.5(N - 15)$$

where

N = actual number of blows recorded in the test

True N = number of blows from which N' should be evaluated

Estimation of allowable bearing pressure from the standard penetration test

Having obtained N' , the determination of the allowable bearing pressure is generally based upon an empirical relationship evolved by Terzaghi and Peck (1948) that is based on the measured settlements of various foundations on sand (Fig. 8.15). The allowable bearing pressure for these curves (which are applicable to both square and rectangular foundations) was defined by Terzaghi and Peck as the pressure that will not cause a settlement greater than 25 mm.

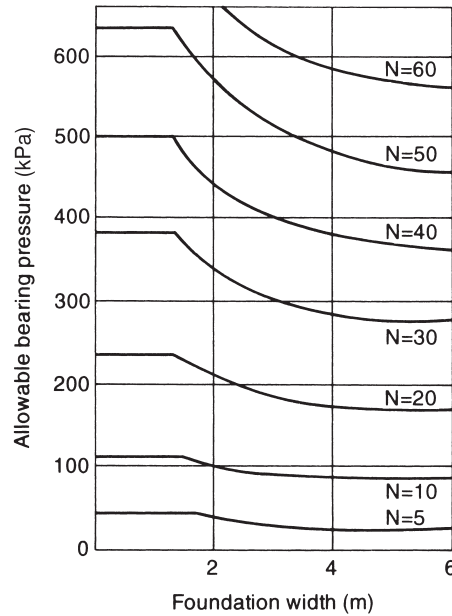
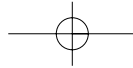
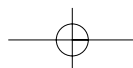

Fig. 8.15 Allowable bearing pressure from the standard penetration test (after Terzaghi and Peck, 1948).

When several foundations are involved the normal design procedure is to determine an average value for N' from all the boreholes. The allowable bearing pressure for the widest foundation is then obtained with this figure and this bearing pressure is used for the design of all the foundations. The procedure generally leads to only small differential settlements, but even in extreme cases the differential settlement between any two foundations will not exceed 20 mm.

The curves of Fig. 8.15 apply to unsaturated soils, i.e. when the water table is at a depth of at least $1.0 B$ below the foundation. When the soil is submerged the value of allowable bearing pressure obtained from the curves should be reduced. Originally the values were reduced to 50 per cent but this is now considered excessively conservative as the influence of the groundwater will have already been included in the observed penetration resistance. General practice is now to apply the 50 per cent reduction if the groundwater level is at or above the foundation level, and to apply no reduction if the groundwater level occurs at a depth of at least B below the foundation level. Between these two limits the amount of reduction can be estimated by linear interpolation.

If settlement is of no consequence it is possible to think in terms of ultimate bearing capacity using the approximate relationship between ϕ' and N' given in Fig. 3.34. Knowing N' , a ϕ' value, from which bearing capacity coefficients are evaluated, can be obtained. This procedure is not generally adopted.



Example 8.8

A granular soil was subjected to standard penetration tests at depths of 3 m. Groundwater level occurred at a depth of 1.5 m below the surface of the soil which was saturated and had a unit weight of 19.3 kN/m^3 . The average N count was 15.

- (i) Determine the corrected value N' .
- (ii) A strip footing, 3 m wide, is to be founded at a depth of 3 m. Assuming that the sand's strength characteristics are constant with depth, determine the allowable bearing pressure.

Solution

(i) Effective overburden pressure = $3 \times 19.3 - 1.5 \times 10 = 43 \text{ kPa}$

From Fig. 8.14, for $\sigma'_v = 43 \text{ kPa}$, $N'/N = 2.1$.

Therefore $N' = 15 \times 2.1 = 31$.

(ii) From Fig. 8.15, for $N' = 31$ and $B = 3 \text{ m}$:

Allowable bearing pressure = 300 kPa

But this value is for *dry* soil and the sand below the foundation is also below groundwater level and is therefore submerged.

It seems that allowable bearing pressure = $\frac{300}{2} = 150 \text{ kPa}$

8.9.3 Correlation between the plate loading and the standard penetration tests

Meigh and Nixon (1961) compared the results of plate loading tests with those of standard penetration tests carried out at the same sites by determining from both sets of results the allowable bearing pressure, p (defined as the pressure causing 25 mm settlement of the foundation) for a 3.05 m square foundation. The differences were quite marked: for fine and silty sands the plate loading test led to values of p about 1.5 times the value obtained from the standard penetration test results, whilst for gravels the plate loading test gave values of p that were from 4 to 6 times greater.

It should be pointed out that Meigh and Nixon used the uncorrected N test values in their calculations, and when Sutherland (1963) examined Meigh and Nixon's results he showed that the disparity between the allowable bearing pressures calculated from the two tests became much less when the corrected N' value (in which overburden pressure is allowed for) was used.

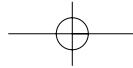

8.9.4 The static cone penetration test

This penetrometer, often called the Dutch cone penetrometer, is headed by a cone of overall diameter 35.7 mm, giving an end area of 1000 mm², and having an apex angle of 60°. The cone is forced downwards at a steady rate (15–20 mm/s) through the soil by means of a load from a hydraulic cylinder transmitted to solid 15 mm diameter rods. These solid rods are centrally placed within 36 mm diameter outer rods. The load acting at the top of the inner rods can be determined from pressure gauge readings and the cone resistance, C_r , is taken to be this load divided by the end area.

Improved forms of the Dutch cone, such as that introduced by Begemann (1965), make it possible to measure cone and side resistances separately, an advantage if the test results are to be used in pile design.

A further development has been the electrical friction–cone penetrometer, described by Lousberg *et al.* (1974), in which the cone penetration resistance is measured and recorded continuously by means of a load cell within the instrument. The penetrometer also has a frictional sleeve connected to a second and independent load cell so that frictional resistance can also be recorded.

A full description of cone penetration testing and its application in geotechnical and geo-environmental engineering is given by Lunne *et al.* (1997).

8.9.5 Presumed bearing capacity

The British Standard BS 8004: 1986 gives a list of safe bearing capacity values and this is reproduced in Table 8.3. The values are based on the following assumptions:

- (i) The site and adjoining sites are reasonably level.
- (ii) The ground strata are reasonably level.
- (iii) There is no softer layer below the foundation stratum.
- (iv) The site is protected from deterioration.

Foundations designed to these values will normally have an adequate factor of safety against bearing capacity failure, provided that they are not subjected to inclined loading, but it must be remembered that settlement effects have not been considered.

For cohesive soils the consistency is related to the undrained strength, c_u . Such a relationship is suggested in BS 5930 and is reproduced in Table 8.4.

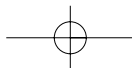
**Table 8.3** Presumed safe bearing capacity, q_s , values (based on BS 8004: 1986).

	q_s (kPa)
<i>Rocks</i>	
(Values based on assumption that foundation is carried down to unweathered rock)	
Hard igneous and gneissic	10 000
Hard sandstones and limestones	4 000
Schists and slates	3 000
Hard shale and mudstones, soft sandstone	2 000
Soft shales and mudstones	1000–600
Hard chalk, soft limestone	600
<i>Cohesionless soils</i>	
(Values to be halved if soil submerged)	
Compact gravel, sand and gravel	>600
Medium dense gravel, or sand and gravel	600–200
Loose gravel, or sand and gravel	<200
Compact sand	>300
Medium dense sand	300–100
Loose sand	<100
<i>Cohesive soils</i>	
(Susceptible to long-term consolidation settlement)	
Very stiff boulder clays and hard clays	600–300
Stiff clays	300–150
Firm clays	150–75
Soft clays and silts	<75
Very soft clays and silts	Not applicable

Table 8.4 Undrained shear strength of cohesive soils.

Consistency	c_u (kPa)	Field behaviour
Hard	>300	Brittle
Very stiff	300–150	Brittle or very tough
Stiff	150–75	Cannot be moulded in fingers
Firm	75–40	Can just be moulded in fingers
Soft	40–20	Easily moulded in fingers
Very soft	<20	Exudes between fingers if squeezed

8.10 Pile foundations

The use of sheet piling, which can be of timber, concrete or steel, for earth retaining structures has been described in Chapter 7. Piled foundations form a separate category and are generally used:

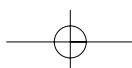

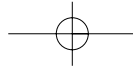

- (i) to transmit a foundation load to a solid soil stratum;
- (ii) to support a foundation by friction of the piles against the soil;
- (iii) to resist a horizontal or uplift load;
- (iv) to compact a loose layer of granular soil.

8.10.1 Classification of piles

Piles can be classified by different criteria, such as their material (e.g. concrete, steel, timber), their method of installation (e.g. driven or bored), the degree of soil displacement during installation, or their size (e.g. large diameter, small diameter). However, in terms of pile design, the most appropriate classification criteria is the behaviour of the pile once installed (e.g. end bearing pile, friction pile, combination pile).

End bearing (Fig. 8.16a)

Derive most of their carrying capacity from the penetration resistance of the soil at the toe of the pile. The pile behaves as an ordinary column and should be designed as such except that, even in weak soil, a pile will not fail by buckling and this effect need only be considered if part of the pile is unsupported, i.e. it is in either air or water.

Friction (Fig. 8.16b)

Carrying capacity is derived mainly from the adhesion or friction of the soil in contact with the shaft of the pile.

Combination (Fig. 8.16c)

Really an extension of the end bearing pile when the bearing stratum is not hard, such as a firm clay. The pile is driven far enough into the lower material to develop adequate frictional resistance. A further variation of the end bearing pile is piles with enlarged bearing areas. This is achieved by forcing a bulb of concrete into the soft stratum immediately above the firm layer to give an enlarged base. A similar effect is

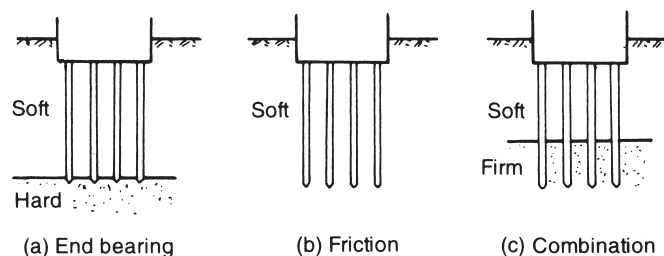
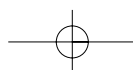

Fig. 8.16 Classification of piles.



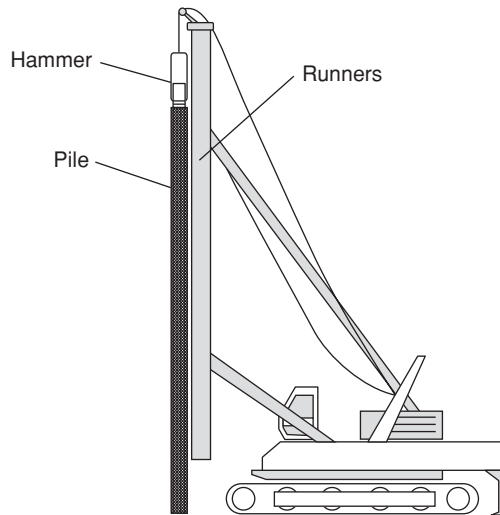

Fig. 8.17 Pile driving rig.

produced with bored piles by forming a large cone or bell at the bottom with a special reaming tool.

8.10.2 Driven piles

These are prefabricated piles that are installed into the ground through the use of a pile driver as illustrated in Fig. 8.17. The pile is hoisted into position on the pile driver and aligned against the runners so that the pile is driven into the ground at exactly the required angle, to exactly the required depth. The pile is driven into the soil by striking the top of the pile repeatedly with a pneumatic or percussive hammer or by driving the pile down using a hydraulic ram. Most commonly the piles are made from precast concrete although timber and steel piles are also available.

Precast concrete

These are usually of square or octagonal section. Reinforcement is necessary within the pile to help withstand both handling and driving stresses. Prestressed concrete piles are also used and are becoming more popular than ordinary precast as less reinforcement is required.

Timber

Timber piles have been used from earliest recorded times and are still used for permanent work where timber is plentiful. In the UK, timber piles are used mainly in temporary works, due to their lightness and shock resistance, but they are also used for piers and fenders and can have a useful life of some 25 years or more if kept

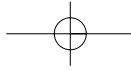

completely below the water table. However, they can deteriorate rapidly if used in ground in which the water level varies and allows the upper part to come above the water surface. Pressure creosoting is the usual method of protection. In tropical climates timber piles above groundwater level are liable to be destroyed by wood-eating insects, sometimes in a matter of weeks.

Steel piles: tubular, box or H-section

These are suitable for handling and driving in long lengths. They have a relatively small cross-sectional area and penetration is easier than with other types. The risk from corrosion is not as great as one might think although tar coating or cathodic protection can be employed in permanent work.

Jetted pile

When driving piles in non-cohesive soils the penetration resistance can often be considerably reduced by jetting a stream of high-pressure water into the soil just below the pile. There have been cases where piles have been installed by jetting alone. The method requires considerable experience, particularly when near to existing foundations.

Vibrated pile

As an alternative to jetting, vibration techniques can be used to place piles in granular soils. Vibrators are not efficient in clays but can be used if piles are to be extracted.

Jacked pile

Generally built up with a series of short sections of precast concrete, this pile is jacked into the ground and progressively increased in length by the addition of a pile section whenever space becomes available. The jacking force is easily measured and the load to pile penetration relationship can be obtained as jacking proceeds. Jacked piles are often used to underpin existing structures where lack of space excludes the use of pile driving hammers.

Screw pile

A screw pile consists of a steel, or concrete, cylinder with helical blades attached to its lower end. The pile is made to screw down into the soil by rotating the cylinder with a capstan at the top of the pile. A screw pile, due to the large size of its screw blades, can offer large uplift resistance.

8.10.3 Driven and cast-in-place piles

Two of the main types of this pile, used in Britain, are described below.

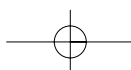

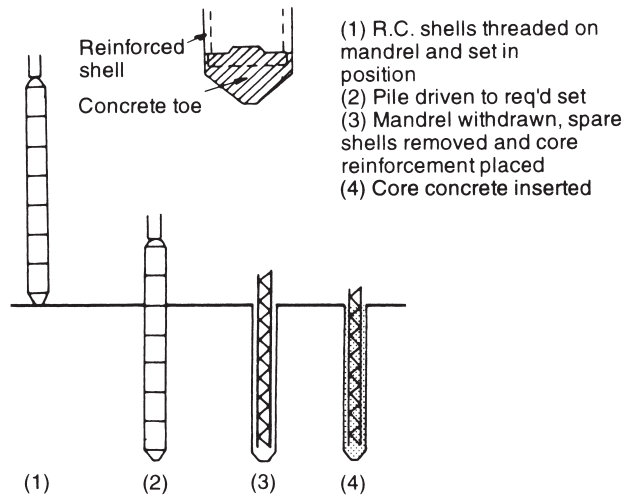

Fig. 8.18 West's shell pile.

West's shell pile

Precast, reinforced concrete tubes, about 1 m long, are threaded on to a steel mandrel and driven into the ground after a concrete shoe has been placed at the front of the shells. Once the shells have been driven to specification the mandrel is withdrawn and reinforced concrete inserted in the core. Diameters vary from 325 to 600 mm. Details of the pile and the method of installation are shown in Fig. 8.18.

Franki pile

A steel tube is erected vertically over the place where the pile is to be driven, and about a metre depth of gravel is placed at the end of the tube. A drop hammer, 1500 to 4000 kg mass, compacts the aggregate into a solid plug which then penetrates the soil and takes the steel tube down with it. When the required set has been achieved the tube is raised slightly and the aggregate broken out. Dry concrete is now added and hammered until a bulb is formed. Reinforcement is placed in position and more dry concrete is placed and rammed until the pile top comes up to ground level. The sequence of operations is illustrated in Fig. 8.19.

8.10.4 Bored and cast-in-situ piles

These piles are formed within a drilled borehole. During the drilling process the sides of the borehole are supported to prevent the soil from collapsing inwards and temporary sections of steel cylindrical casing are advanced along with the drilling process to provide this required support. As the drilling progresses, the soil is removed from within the casing and brought to the surface. Once the full depth of the borehole has been reached, the casing is gradually withdrawn, the reinforcement cage is placed

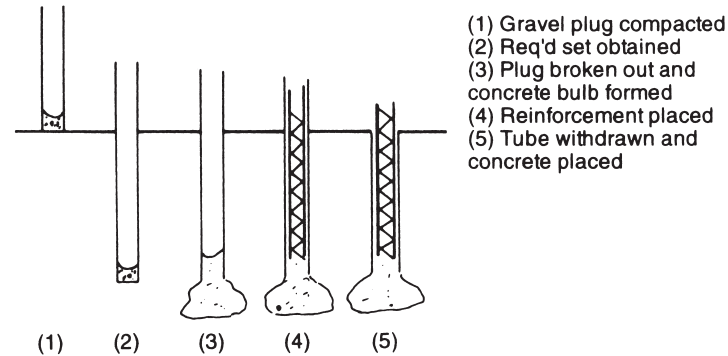
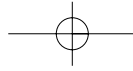

Fig. 8.19 Installation of a Franki pile.

and the concrete which forms the pile is pumped into the borehole. For very deep boreholes the installation of many sections of temporary casing can be an expensive and slow process, and an alternative means of supporting the sides is through the use of a bentonite slurry in the same manner as for a diaphragm wall (see Section 7.3.2).

An alternative technique which does not use borehole side-support is the *continuous flight auger (CFA)* pile. With this technique a continuous flight auger with a hollow stem is used to create the borehole. The sides of the borehole are supported by the soil on the flights of the auger and so no casing is required. Once the required depth has been reached, the concrete is pumped down the hollow stem and the auger is steadily withdrawn. The steel reinforcement is placed once the auger is clear of the borehole.

8.10.5 Large diameter bored piles

The driven or bored and cast-in-place piles discussed previously generally have maximum diameters in the order of 0.6 m and are capable of working loads round about 2 MN. With modern buildings column loads in the order of 20 MN are not uncommon. A column carrying such a load would need about ten conventional piles, placed in a group and capped by a concrete slab, probably some 25 m² in area.

A consequence of this problem has been the increasing use of the large diameter bored pile. This pile has a minimum shaft diameter of 0.75 m and may be under-reamed to give a larger bearing area if necessary. Such a pile is capable of working loads in the order of 25 MN and, if taken down through the soft to the hard material, will minimise settlement problems so that only one such pile is required to support each column of the building. Large diameter bored piles have been installed in depths down to 60 m.

8.10.6 Determination of the bearing capacity of a pile by load tests

The load test is the only really reliable means of determining a pile's load capacity, but it is expensive, particularly if the ground is variable and a large number of piles must therefore be tested.

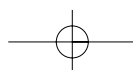

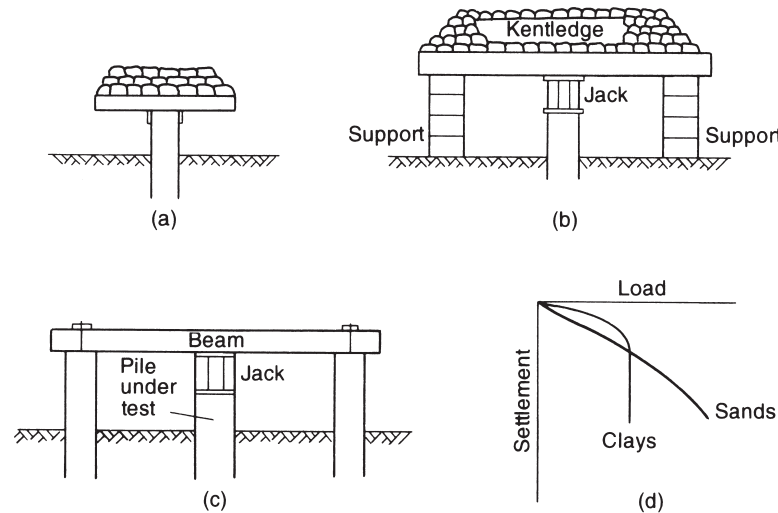

Fig. 8.20 (a)–(c) Methods for testing a pile. (d) Load to settlement relationship.

Full-scale piles should be used—and these should be driven in the same manner as those placed for the permanent work.

Figure 8.20 gives rough indications of how a test pile may be loaded. A large mass of dead weight is placed on a platform supported by the pile. The load is applied in increments and the settlement is recorded when the rate of settlement has reduced to 0.25 mm in an hour, at which stage a further increment can be applied (Fig. 8.20a). The method has the disadvantage that the platform must be balanced on top of the pile and there is always the risk of collapse. An alternative, and better, technique is to jack the pile against a kentledge using an arrangement similar to Fig. 8.20b.

Sometimes the piles to be used permanently can be used to test a pile as shown in Fig. 8.20c.

The form of load to settlement relationship obtained from a loading test is shown in Fig. 8.20d. Loading is continued until failure occurs, except for large diameter bored piles which, having a working load of some 25 MN, would require massive kentledges if failure loads were to be achieved. General practice has become to test load these piles to the working load plus 50 per cent.

Design standards offer some limited guidance on static load pile test methods. BS 8004 specifies two types of test, described below, from which the ultimate load of a pile can be obtained, and Eurocode 7 (see Section 8.11) makes reference to the ASTM suggested method for the axial pile loading test, described by Smolczyk (1985). Furthermore, it is likely that the forthcoming European standard for pile testing will adopt the recommendations and procedures described by De Cock *et al.* (2003).

(1) The maintained load test

Here the load is applied to the pile in a series of increments, usually equal to 25 per cent of the designated working load for the pile. The ultimate pile load is taken to be the load that achieves some specified amount of settlement, usually 10 per cent of the pile's diameter.

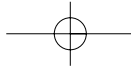

(2) The constant rate of penetration test

In this test the pile is jacked downwards at a constant rate of penetration. The ultimate pile load is considered to be the load at which either a shear failure takes place within the soil or the penetration of the pile equals 10 per cent of its diameter.

The figure of one tenth is intended for normal sized piles and, if applied to large diameter bored piles, could lead to excessive settlements if a factor of safety of 2.5 were adopted. This, of course, only applies to large diameter piles resting on soft rocks. In the case of a large diameter bored pile resting on hard rock the ultimate load depends upon the ultimate stress in the concrete.

8.10.7 Determination of the bearing capacity of a pile by soil mechanics

A pile is supported in the soil by the resistance of the toe to further penetration plus the frictional or adhesive forces along its embedded length.

Ultimate bearing capacity = Ultimate base resistance + Ultimate skin friction:

$$Q_u = Q_b + Q_s$$

Cohesive soils

Q_b for piles in cohesive soils is based on Meyerhof's equation (1951):

$$Q_b = N_c \times c_b \times A_b$$

where

N_c = bearing capacity factor, widely accepted as equal to 9.0

c_b = undisturbed undrained shear strength of the soil at base of pile.

Q_s is given by the equation:

$$Q_s = \alpha \times \bar{c}_u \times A_s$$

where

α = adhesion factor

\bar{c}_u = average undisturbed undrained shear strength of soil adjoining pile

A_s = surface area of embedded length of pile.

Hence

$$Q_u = c_b N_c A_b + \alpha \bar{c}_u A_s$$

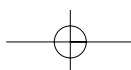

The adhesion factor α

Most of the bearing capacity of a pile in cohesive soil is derived from its shaft resistance, and the problem of determining the ultimate load resolves into determining a value for α . For soft clays α can be equal to or greater than 1.0 as, after driving, soft clays tend to increase in strength. In overconsolidated clays α has been found to vary from 0.3 to 0.6. The usual value assumed for London clay was, for many years, taken as 0.45 but more recently a value of 0.6 for this type of soil has become more accepted.

Cohesionless soils

The ultimate load of a pile installed in cohesionless soil is estimated using only the value of the drained parameter, ϕ' , and assuming that any contribution due to c' is zero.

$$Q_b = q_b A_b = \sigma'_v N_q A_b$$

where

- σ'_v = the effective overburden pressure at the base of the pile
- N_q = the bearing capacity coefficient
- A_b = the area of the pile base.

The selection of a suitable value for N_q is obviously a crucial part of the design of the pile. The values suggested by Berezantzev *et al.* (1961) are often used and are reproduced in Fig. 8.21. Note that the full value of N_q is used as it is assumed that the weight of soil removed or displaced is equal to the weight of the pile that replaced it.

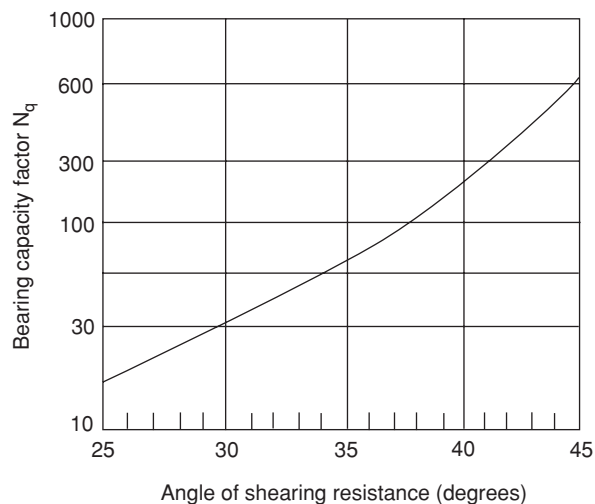
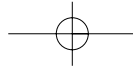

Fig. 8.21 Bearing capacity factor N_q (after Berezantzev *et al.*, 1961).



$$Q_s = f_s A_s$$

where

f_s = average value of the ultimate skin friction over the embedded length of the pile

A_s = surface area of embedded length of pile.

Meyerhof (1959) suggested that for the average value of the ultimate skin friction:

$$f_s = K_s \bar{\sigma}_v \tan \delta$$

where

K_s = the coefficient of lateral earth pressure

$\bar{\sigma}_v$ = average effective overburden pressure acting along the embedded length of the pile shaft

δ = angle of friction between the pile and the soil.

Hence

$$Q_s = A_s K_s \bar{\sigma}_v \tan \delta$$

and

$$Q_u = \sigma'_v N_q A_b + A_s K_s \bar{\sigma}_v \tan \delta$$

Typical values for δ and K_s were derived by Broms (1966), and are listed in Table 8.5.

Vesic (1973) pointed out that the value of q_b , i.e. $\sigma'_v N_q$, does not increase indefinitely but has a limiting value at a depth of some 20 times the pile diameter. There is therefore a maximum value of $\sigma'_v N_q$ that can be used in the calculations for Q_b .

In a similar manner there is a limiting value that can be used for the average ultimate skin friction, f_s . This maximum value of f_s occurs when the pile has an embedded

Table 8.5 Typical values for δ and K_s suggested by Broms (1966).

Pile material	δ	K_s	
		Relative density of soil	
		Loose	Dense
Steel	20°	0.5	1.0
Concrete	0.75 ϕ'	1.0	2.0
Timber	0.67 ϕ'	1.5	4.0

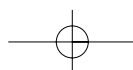

length between 10 and 20 pile diameters. Vesic (1970) suggested that the maximum value of the average ultimate skin resistance should be obtained from the formula:

$$f_s = 0.08(10)^{1.5(D_r)^4}$$

where D_r = the relative density of the cohesionless soil.

In practice f_s is often taken as 100 kPa if the formula gives a greater value.

Unlike piles embedded in cohesive soils, the end resistances of piles in cohesionless soils are of considerable significance and short piles are therefore more efficient in cohesionless soils.

8.10.8 Determination of soil piling parameters from in situ tests

With cohesionless soils it is possible to make reasonable estimates of the values of q_b and f_s from *in situ* penetration tests. Meyerhof (1976) suggests the following formulae to be used in conjunction with the standard penetration test.

Driven piles

Sands and gravel	$q_b \approx \frac{40ND}{B} \leq 400N \text{ (kPa)}$
------------------	--

Non-plastic silts	$q_b \approx \frac{40ND}{B} \leq 300N \text{ (kPa)}$
-------------------	--

Bored piles

Any type of granular soil	$q_b \approx \frac{14ND}{B} \text{ kPa}$
---------------------------	--

Large diameter driven piles	$f_s \approx 2\bar{N} \text{ kPa}$
-----------------------------	------------------------------------

Average diameter driven piles	$f_s \approx \bar{N} \text{ kPa}$
-------------------------------	-----------------------------------

Bored piles	$f_s \approx 0.67\bar{N} \text{ kPa}$
-------------	---------------------------------------

where

N = the *uncorrected* blow count at the pile base

\bar{N} = the average *uncorrected* N value over the embedded length of the pile

D = embedded length of the pile in the end bearing stratum

B = width, or diameter, of pile.

An alternative method is to use the results of the Dutch cone test. Typical results from such a test are shown in Fig. 8.22 and are given in the form of a plot showing the variation of the cone penetrations resistance with depth.

For the ultimate base resistance, C_r , the cone resistance is taken as being the average value of C_r over the depth $4d$ as shown, where d = diameter of shaft. Then:

$$Q_b = C_r A_b$$

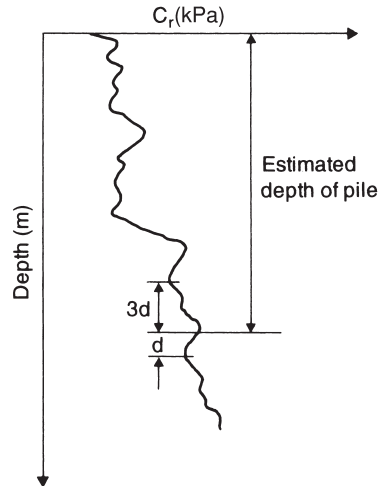
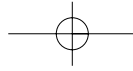

Fig. 8.22 Typical results from a Dutch cone test.

The ultimate skin friction, f_s , can be obtained from one of the following:

$$f_s \approx \frac{\bar{C}_r}{200} \text{ kPa} \quad \text{for driven piles in dense sand}$$

$$f_s \approx \frac{\bar{C}_r}{400} \text{ kPa} \quad \text{for driven piles in loose sand}$$

$$f_s \approx \frac{\bar{C}_r}{150} \text{ kPa} \quad \text{for driven piles in non-plastic silts}$$

where \bar{C}_r = average cone resistance along the embedded length of the pile (De Beer, 1963).

Then $Q_s = f_s A_s$ and, as before, $Q_u = Q_b + Q_s$.

Example 8.9

A 5 m thick layer of medium sand overlies a deep deposit of dense gravel. A series of standard penetration tests carried out through the depth of the sand has established that the average blow count, \bar{N} , is 22. Further tests show that the gravel has a standard penetration value of $N = 40$ in the region of the interface with the sand. A precast pile of square section $0.25 \times 0.25 \text{ m}^2$ is to be driven down through the sand and to penetrate sufficiently into the gravel to give good end bearing.

Adopting a safety factor of 3.0 determine the allowable load that the pile will be able to carry.

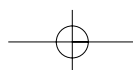

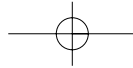
*Solution*

$$\text{Ultimate bearing capacity of the pile} = Q_u = Q_s + Q_b$$

Q_b : All end bearing effects will occur in the gravel. Now

$$q_b \approx 40 N \frac{D}{B} \text{ kPa or } 400 \times N \text{ kPa (whichever is the lesser)}$$

i.e.

$$q_b = 40 \times 40 \times \frac{D}{0.25} = 400 \times 40 = 16\,000 \text{ kPa}$$

$$\text{Penetration into gravel, } D, = \frac{16\,000 \times 0.25}{40 \times 40} = 2.5 \text{ m}$$

and

$$Q_b = 16\,000 \times 0.25^2 = 1000 \text{ kN}$$

$$Q_s \text{ in sand: } Q_s = f_s A_s = 22 \times 5 \times 0.25 \times 4 = 110 \text{ kN}$$

$$Q_s \text{ in gravel: } Q_s = f_s A_s = 40 \times 2.5 \times 0.25 \times 4 = 100 \text{ kN}$$

i.e.

$$Q_u = 210 + 1000 = 1210 \text{ kN}$$

$$\text{Allowable load} = \frac{1210}{3} = 400 \text{ kN}$$

Example 8.9 illustrates that, as discussed earlier, the end bearing effects are much greater than those due to side friction. It can be argued that, in order to develop side friction (shaft resistance) fully, a significant downward movement of the pile is required which cannot occur in this example because of the end resistance of the gravel. As a result of this phenomenon, it is common practice to apply a different factor of safety to the shaft resistance than that applied to the end bearing resistance. Typically a factor of safety of around 1.5 is applied to shaft resistance, and a factor of safety between 2.5 and 3.0 is applied to the end bearing resistance.

Returning to Example 8.9, and adopting $F_b = 3$, $F_s = 1.5$, the allowable load now becomes:

$$\frac{1000}{3} + \frac{210}{1.5} = 473 \text{ kN}$$

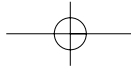

Negative skin friction

If a soil subsides or consolidates around a group of piles these piles will tend to support the soil and there can be a considerable increase in the load on the piles.

The main causes for this state of affairs are that:

- (i) bearing piles have been driven into recently placed fill;
- (ii) fill has been placed around the piles after driving.

If negative friction effects are likely to occur then the piles must be designed to carry the additional load. In extreme cases the value of negative skin friction can equal the positive skin friction but, of course, this maximum value cannot act over the entire bedded length of the pile, being virtually zero at the top of the pile and reaching some maximum value at its base.

8.11 Designing pile foundations to Eurocode 7

The principles of Eurocode 7, as described in Section 7.4.2, apply to the design of pile foundations, and the reader is advised to refer back to that section whilst studying the following few pages.

The design of pile foundations is covered in Section 7 of Eurocode 7. There are 11 limit states listed that should be considered, though only those limit states most relevant to the particular situation would normally be considered in the design. These include the loss of overall stability, bearing resistance failure of the pile, uplift of the pile and structural failure of the pile. In this chapter we will look only at checking against ground resistance failure through the compressive loading of the pile.

Pile design methods acceptable to Eurocode 7 are in the main based on the results of static pile load tests, and the design calculations should be validated against the test results. When considering the compressive ground resistance limit state the task is to demonstrate that the design axial compression load on a pile or pile group, $F_{c;d}$, is less than or equal to the design compressive ground resistance, $R_{c;d}$, against the pile or pile group. In the case of pile groups, $R_{c;d}$ is taken as the lesser value of the design ground resistance of an individual pile and that of the whole group.

In keeping with the rules of Eurocode 7, the design value of the compressive resistance of the ground is obtained by dividing the characteristic value by a partial factor of safety. The characteristic value is obtained by one of three approaches: from static load tests, from ground tests results or from dynamic tests results.

(i) Ultimate compressive resistance from static load tests

The characteristic value of the compressive ground resistance, $R_{c;k}$, is obtained by combining the measured value from the pile load tests with a correlation factor, ξ (related to the number of piles tested). More explicitly, $R_{c;k}$ is taken as the lesser value of:

$$R_{c;k} = \frac{(R_{c;m})_{\text{mean}}}{\xi_1} \quad \text{and} \quad R_{c;k} = \frac{(R_{c;m})_{\text{min}}}{\xi_2}$$

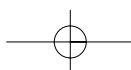

where

- $(R_{c;m})_{\text{mean}}$ = the mean measured resistance
 $(R_{c;m})_{\text{min}}$ = the minimum measured resistance
 ξ_1, ξ_2 = correlation factors obtained from Table 8.6.

Table 8.6 Correlation factors – static load tests results.

	Number of piles tested				
	1	2	3	4	≥ 5
ξ_1	1.4	1.3	1.2	1.1	1.0
ξ_2	1.4	1.2	1.05	1.0	1.0

It may be that the characteristic compressive resistance of the ground is more appropriately determined from the characteristic values of the base resistance, $R_{b;k}$ and the shaft resistance, $R_{s;k}$:

$$R_{c;k} = R_{b;k} + R_{s;k}$$

The design compressive resistance of the ground may be derived by either:

$$R_{c;d} = \frac{R_{c;k}}{\gamma_t}$$

or

$$R_{c;d} = \frac{R_{b;k}}{\gamma_b} + \frac{R_{s;k}}{\gamma_s}$$

where γ_b , γ_s and γ_t are partial factors on base resistance, shaft resistance and the total resistance respectively. The partial factors for piles in compression recommended in Eurocode 7 are given in Table 8.7.

Considering Design Approach 1, the following partial factor sets (see Section 7.4.2) are used for the design of axially loaded piles:

- Combination 1: A1 + M1 + R1
 Combination 2: A2 + (M1 or M2)* + R4

* M1 is used for calculating pile resistance; M2 is used for calculating unfavourable actions on piles.

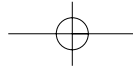
**Table 8.7** Piles in compression: partial factor sets R1, R2, R3 and R4.

Partial factor set	R1			R2	R3	R4		
	Driven	Bored	CFA	All	All	Driven	Bored	CFA
Base, γ_b	1.0	1.25	1.1	1.1	1.0	1.3	1.6	1.45
Shaft, γ_s	1.0	1.00	1.0	1.1	1.0	1.3	1.3	1.30
Total, γ_t	1.0	1.15	1.1	1.1	1.0	1.3	1.5	1.40

Example 8.10

A series of static load tests on a set of four bored piles gave the following results:

	Test no.			
	1	2	3	4
Measured load (kN)	382	425	365	412

From an understanding of the ground conditions, it is assumed that the ratio of base resistance to shaft resistance is 3:1.

Determine the design compressive resistance of the ground in accordance with Eurocode 7, Design Approach 1.

Solution

$$(R_{c;m})_{\text{mean}} = \frac{382 + 425 + 365 + 412}{4} = 396 \text{ kN}$$

$$(R_{c;m})_{\text{min}} = 365 \text{ kN}$$

From Table 8.6, $\xi_1 = 1.1$; $\xi_2 = 1.0$

$$R_{c;k} = \frac{(R_{c;m})_{\text{mean}}}{\xi_1} = \frac{396}{1.1} = 360 \text{ kN}$$

$$R_{c;k} = \frac{(R_{c;m})_{\text{min}}}{\xi_2} = \frac{365}{1.0} = 365 \text{ kN}$$

that is

$$R_{c;k} = 360 \text{ kN} \quad (\text{i.e. the minimum value})$$

Since the ratio of base resistance to shaft resistance is 3:1, we have:

$$\text{Characteristic base resistance, } R_{b;k} = 360 \times 0.75 = 270 \text{ kN}$$

$$\text{Characteristic shaft resistance, } R_{s;k} = 360 \times 0.25 = 90 \text{ kN}$$

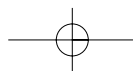

1. Design Approach 1, Combination 1

Partial factor set R1 is used:

$$R_{c;d} = \frac{R_{c;k}}{\gamma_t} = \frac{360}{1.15} = 313 \text{ kN}$$

or

$$R_{c;d} = \frac{R_{b;k}}{\gamma_b} + \frac{R_{s;k}}{\gamma_s} = \frac{270}{1.25} + \frac{90}{1.0} = 306 \text{ kN}$$

2. Design Approach 1, Combination 2

Partial factor set R4 is used:

$$R_{c;d} = \frac{R_{c;k}}{\gamma_t} = \frac{360}{1.5} = 240 \text{ kN}$$

or

$$R_{c;d} = \frac{R_{b;k}}{\gamma_b} + \frac{R_{s;k}}{\gamma_s} = \frac{270}{1.6} + \frac{90}{1.3} = 238 \text{ kN}$$

The design compressive resistance of the ground is thus determined:

$$R_{c;d} = \min(313, 306, 240, 238) = 238 \text{ kN}$$

(ii) Ultimate compressive resistance from ground tests results

The design compressive resistance can be determined from ground tests results. Here the characteristic compressive resistance, $R_{c;k}$, is taken as the lesser value of:

$$R_{c;k} = \frac{(R_{b;cal} + R_{s;cal})_{mean}}{\xi_3} \quad \text{and} \quad R_{c;k} = \frac{(R_{b;cal} + R_{s;cal})_{min}}{\xi_4}$$

where

- $(R_{b;cal})_{mean}$ = the mean calculated base resistance
- $(R_{s;cal})_{mean}$ = the mean calculated shaft resistance
- $(R_{b;cal})_{min}$ = the minimum calculated base resistance
- $(R_{s;cal})_{min}$ = the minimum calculated shaft resistance
- ξ_3, ξ_4 = correlation factors obtained from Table 8.8.

The calculated base and shaft resistances are determined using the equations set out in Section 8.10.7.

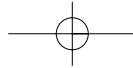
**Table 8.8** Correlation factors – ground tests results.

	Number of test profiles						
	1	2	3	4	5	7	10
ξ_3	1.4	1.35	1.33	1.31	1.29	1.27	1.25
ξ_4	1.4	1.27	1.23	1.20	1.15	1.12	1.08

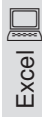
**Example 8.11**

A 10 m long by 0.7 m diameter CFA pile is to be founded in a uniform soft clay. The following test results were established in a geotechnical laboratory as part of a site investigation:

Borehole no.	1	2	3	4
Mean undrained strength along shaft, $c_{u,shaft}$ (kPa)	65	62	70	73
Mean undrained strength at base, $c_{u,base}$ (kPa)	90	79	96	100

The pile will carry a permanent axial load of 500 kN (includes the self-weight of the pile) and an applied transient (variable) axial load of 150 kN.

Check the bearing resistance (GEO) limit state in accordance with Eurocode 7, Design Approach 1 by establishing the magnitude of the over-design factor. Assume $N_c = 9$ and $\alpha = 0.7$.

Solution

$$\text{Area of base of pile, } A_b = \frac{\pi D^2}{4} = \frac{\pi \times 0.7^2}{4} = 0.385 \text{ m}^2$$

The total resistance is determined from the results from each borehole:

$$\begin{aligned} (R_{b,cal})_1 &= (N_c \times c_u \times A_b) + (\pi \times D \times L \times \alpha \times c_u) \\ &= (9 \times 90 \times 0.385) + (\pi \times 0.7 \times 10 \times 0.7 \times 65) = 1312 \text{ kN} \\ (R_{b,cal})_2 &= (9 \times 79 \times 0.385) + (\pi \times 0.7 \times 10 \times 0.7 \times 62) = 1228 \text{ kN} \\ (R_{b,cal})_3 &= (9 \times 96 \times 0.385) + (\pi \times 0.7 \times 10 \times 0.7 \times 70) = 1410 \text{ kN} \\ (R_{b,cal})_4 &= (9 \times 100 \times 0.385) + (\pi \times 0.7 \times 10 \times 0.7 \times 73) = 1470 \text{ kN} \end{aligned}$$

$$(R_{c,cal})_{\text{mean}} = \frac{1312 + 1228 + 1410 + 1470}{4} = 1355 \text{ kN}$$

$$(R_{c,cal})_{\text{min}} = 1228 \text{ kN} \quad (\text{i.e. Borehole 2})$$

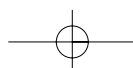

From Table 8.8, $\xi_3 = 1.31$; $\xi_4 = 1.2$.

$$R_{c;k} = \frac{(R_{c;cal})_{\text{mean}}}{\xi_3} = \frac{1355}{1.31} = 1034 \text{ kN}$$

$$R_{c;k} = \frac{(R_{c;cal})_{\text{min}}}{\xi_4} = \frac{1228}{1.2} = 1023 \text{ kN}$$

that is, $(R_{c;cal})_{\text{min}}$ governs and this lower value of $R_{c;k}$ is taken as the characteristic compressive resistance.

Therefore, using ξ_4 :

$$\text{Characteristic base resistance, } R_{b;k} = \frac{9 \times 79 \times 0.385}{1.20} = 228 \text{ kN}$$

$$\text{Characteristic shaft resistance, } R_{s;k} = \frac{\pi \times 0.7 \times 10 \times 0.7 \times 62}{1.20} = 795 \text{ kN}$$

1. Design Approach 1, Combination 1:

Design resistance: partial factor set R1 is used (Table 8.7):

$$R_{c;d} = \frac{R_{b;k}}{\gamma_b} + \frac{R_{s;k}}{\gamma_s} = \frac{228}{1.1} + \frac{795}{1.0} = 1002 \text{ kN}$$

Design actions: partial factor set A1 is used (Table 7.1):

$$F_{c;d} = 500 \times 1.35 + 150 \times 1.5 = 900 \text{ kN}$$

$$\text{Over-design factor, } \Gamma = \frac{1002}{900} = 1.11$$

2. Design Approach 1, Combination 2:

Design resistance: partial factor set R4 is used (Table 8.7):

$$R_{c;d} = \frac{R_{b;k}}{\gamma_b} + \frac{R_{s;k}}{\gamma_s} = \frac{228}{1.45} + \frac{795}{1.3} = 769 \text{ kN}$$

Design actions: partial factor set A2 is used (Table 7.1):

$$F_{c;d} = 500 \times 1.0 + 150 \times 1.3 = 695 \text{ kN}$$

$$\text{Over-design factor, } \Gamma = \frac{769}{695} = 1.11$$

Since $\Gamma \geq 1$, the design of the pile satisfies the GEO limit state requirement.

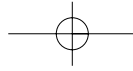

(iii) *Ultimate compressive resistance from dynamic tests results*

Although static load tests and ground tests are the most common methods of determining the compressive resistance of the pile, the resistance can also be estimated from dynamic tests provided that the test procedure has been calibrated against static load tests.

8.12 Pile groups

8.12.1 Action of pile groups

Piles are usually driven in groups (see Fig. 8.23).

In the case of end bearing piles the pressure bulbs of the individual piles will overlap (if spacing $< 5d$ – the usual condition). Provided that the bearing strata are firm throughout the affected depth of this combined bulb then the bearing capacity of the group will be equal to the summation of the individual strengths of the piles. However, if there is a compressible soil layer beneath the firm layer in which the piles are founded, care must be taken to ensure that this weaker layer is not overstressed.

Pile groups in cohesionless soils

Pile driving in sands and gravels compacts the soil between the piles. This compactive effect can make the bearing capacity of the pile group greater than the sum of the individual pile strengths. Spacing of piles is usually from two to three times the diameter, or breadth, of the piles.

Pile groups in cohesive soils

A pile group placed in a cohesive soil has a collective strength which is considerably less than the summation of the individual pile strengths which compose it.

One characteristic of pile groups in cohesive soils is the phenomenon of 'block failure'. If the piles are placed very close together (a common temptation when

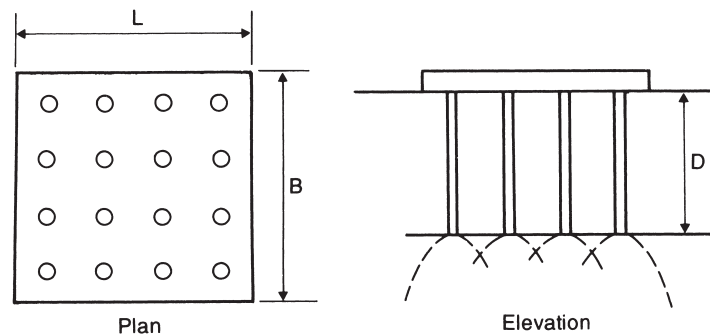
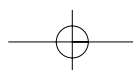

Fig. 8.23 A typical pile group.



dealing with a limited site area), the strength of the groups may be governed by its strength at block failure. This is when the soil fails along the perimeter of the group.

For block failure:

$$Q_u = 2D(B + L) \times \bar{c}_u + 1.3c_b N_c BL$$

where

D = depth of pile penetration

L = length of pile group

B = breadth of pile group

N_c = bearing capacity coefficient (taken generally as 9.0).

Whitaker (1957), in a series of model tests, showed that block failure will not occur if the piles are spaced at not less than 1.5d apart. General practice is to use 2d to 3d spacings.

In such cases:

$$Q_u = En Q_{up}$$

where

E = efficiency of pile group (0.7 for spacings 2d–3d)

Q_{up} = ultimate bearing capacity of single pile

n = number of piles in group.

8.12.2 Settlement effects in pile groups

Quite often it is the allowable settlement, rather than the safe bearing capacity, that decides the working load that a pile group may carry.

For bearing piles the total foundation load is assumed to act at the base of the piles on a foundation of the same size as the plan of the pile group. With this assumption it becomes a simple matter to examine settlement effects.

With friction piles it is virtually impossible to determine the level at which the foundation load is effectively transferred to the soil. An approximate method, often used in design, is to assume that the effective transfer level is at a depth of $2D/3$ below the top of the piles. It is also assumed that there is a spread of the total load, one horizontal to four vertical. The settlement of this equivalent foundation (Fig. 8.24) can then be determined by the normal methods.

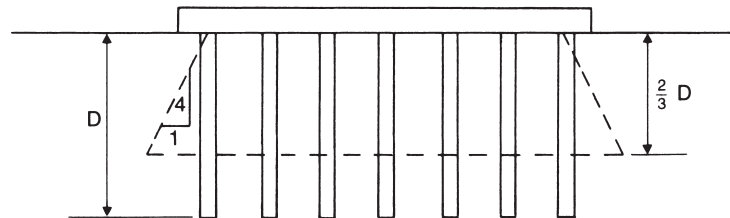
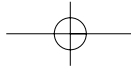

Fig. 8.24 Transference of load in friction piles.



Exercises

Note Where applicable the answers quoted incorporate a factor of safety equal to 3.0.

Exercise 8.1

A fine sand deposit is saturated throughout with a unit weight of 20 kN/m^3 . Ground water level is at a depth of 1 m below the surface. A standard penetration test, carried out at a depth of 2 m, gave an N value of 18. If the settlement is to be limited to not more than 25 mm, determine an allowable bearing pressure value for a 2 m square foundation founded at a depth of 2 m.

Answers $460/2 = 230 \text{ kPa}$ ($N \approx 40$)

Exercise 8.2

A strip footing 3 m wide is to be founded at a depth of 2 m in a saturated soil of unit weight 19 kN/m^3 . The soil has an angle of friction, ϕ , of 28° and a cohesion, c , of 5 kPa. Groundwater level is at a depth of 4 m. Determine a value for the safe bearing capacity of the foundation.

If the groundwater level was to rise to the ground surface, determine the new value of safe bearing capacity.

Answer 459 kPa; 249 kPa

Exercise 8.3

A 2.44 m wide strip footing is to be founded in a coarse sand at a depth of 3.05 m. The unit weight of the sand is 19.3 kN/m^3 and standard penetration tests at the 3.05 m depth gave an N value of 12.

- (i) Determine the safe bearing capacity of the foundation if settlement is of no account.
- (ii) Determine the allowable bearing pressure if settlement of the foundation is not to exceed 25 mm.

Answers (i) 1300 kPa, (ii) 300 kPa

Exercise 8.4

A single test pile, 300 mm diameter, is driven through a depth of 8 m of clay which has an undrained cohesive strength varying from 10 kPa at its surface to 50 kPa at a depth of 8 m. Estimate the safe load that the pile can carry.

Answer 60 kN

Exercise 8.5

A continuous concrete footing ($\gamma_c = 24 \text{ kN/m}^3$) of breadth 2.0 m and thickness 0.5 m is to be founded in a clay soil ($\phi_u = 0^\circ$; $c_u = 22 \text{ kPa}$; $\gamma = 19 \text{ kN/m}^3$) at a depth of 1.0 m. The footing will carry an applied vertical load of magnitude 85 kN per metre run. The load will act on the centre-line of the footing.

Using Eurocode 7 Design Approach 1, determine the magnitude of the over-design factor for both Combination 1 and Combination 2.

Answer 1.53 (DA1-1); 1.56 (DA1-2)

If you were to include depth factors in the design procedure, what would be the revised value of the over-design factor for each combination?

Answer 1.79 (DA1-1); 1.81 (DA1-2)

Note: Adopting depth factors in the design will invariably lead to higher values of over-design factor.

Exercise 8.6

A rectangular foundation ($2.5 \text{ m} \times 6 \text{ m} \times 0.8 \text{ m}$ deep) is to be founded at a depth of 1.2 m in a dense sand ($c' = 0$; $\phi' = 32^\circ$; $\gamma = 19.4 \text{ kN/m}^3$). The unit weight of concrete = 24 kN/m^3 . The foundation will carry a vertical line load of 250 kN/m at an eccentricity of 0.4 m.

By following Eurocode 7, Design Approach 1 establish the proportion of the available resistance that will be used.

Answer 16 per cent (DA1-1); 24 per cent (DA1-2)

Note: The proportion of available resistance that will be used is determined by taking the reciprocal of the over-design factor.

