

# chapter 9

## Head-to-Head Movement

### 0. INTRODUCTION

Consider the relation between a verb and its object: According to X-bar theory, an object is the complement to V (sister to V, daughter of V'). This means that *no* specifier or adjunct can intervene between the complement and the head (if they did, the object would no longer be a complement).

The following sentence is from Modern Irish Gaelic, this is a Verb-Subject-Object (VSO) word order language:

- 1) Phóg Máire an lucharachán.  
Kissed Mary the leprechaun  
"Mary kissed the leprechaun."

In this sentence, the subject (a specifier) intervenes between the verb and the object; this sentence cannot be generated by X-bar theory. (Try to draw a tree where the specifier intervenes between the head and the complement – it's impossible.)

Now consider the following sentence from French:

- 2) Je mange souvent des pommes.  
I eat often of.the apples  
"I often eat apples."

*Souvent* "often" intervenes between the verb and the object. If *souvent* is an adjunct it is appearing between a head and its complement. X-bar theory can't draw the tree for this one either.

In sum, X-bar theory *undergenerates*, it does not produce all the possible grammatical sentences in a language.

Although based on very different problems than the ones in (1) and (2), Chomsky (1957) observed that a phrase structure grammar (such as X-bar theory) cannot generate all the sentences of a language. He proposed that what was needed was a set of rules that change the structure (in very limited ways) generated by phrase structure rules. These rules are called *transformational rules*. Transformations take the output of X-bar rules (and other transformations) and change them into different trees.

The model of grammar that we are suggesting here takes the following form. You should read this like a flow chart. The derivation of a sentence starts at the top, and what comes out at the bottom is what you say.

3)

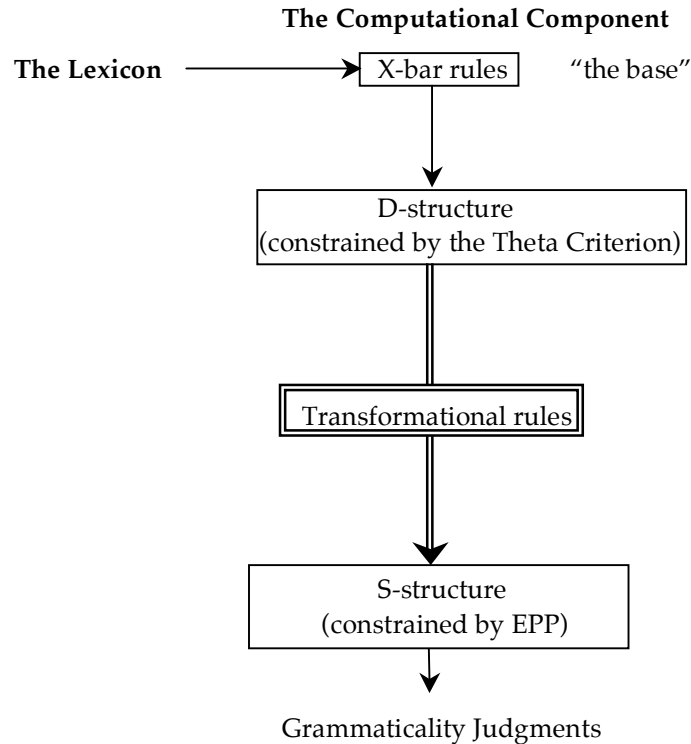

X-bar theory and the lexicon conspire together to generate trees. This conspiracy is called *the base*. The result of this tree generation is a level we call *D-structure* (this used to be called Deep Structure, but for reasons that need not concern us here, the name has changed to D-structure). You will never pronounce a D-structure. D-structure is also sometimes called the *underlying form* or *underlying representation* (and is similar in

many ways to the underlying form found in phonology). The theta criterion filters out ungrammatical sentences at D-structure.

D-structure is then subject to the *transformational rules*. These transformational rules can move words around in the sentence. We've actually already seen two of these transformational rules. In Chapter 7, we looked briefly at T to C movement in subject-aux inversion constructions, and affix lowering, which gets inflectional suffixes to lower to their verb. (In this chapter, we're going to look in more detail at these two rules.) The output of a transformational rule is called the *S-structure* of a sentence. The S-structure is filtered by the EPP, which ensures that the sentence has a subject. What are left are grammatical sentences.

In the version of Chomskyan grammar we are considering, we will look at two different kinds of transformations: movement rules and insertion rules. Movement rules move things around in the sentence. Insertion rules put something new into the sentence. This chapter is about one kind of movement rule: the rules that move one head into another, called *head-to-head movement*. These transformational rules will allow us to generate sentences like (1) and (2) above. X-bar theory by itself cannot produce these structures.

#### Generative Power

Before we go any further and look at an example of a transformation, consider the power of this type of rule. A transformation is a rule that can change the trees built by X-bar theory. If you think about it, you'll see that such a device is extremely powerful; in principle it could do *anything*. For example you could write a changing rule that turns all sentences that have the word "red" in them to sentences with SOV order.

i)  $[_{TP} \dots \text{red} \dots] \Rightarrow [_{TP} S [O V]]$

This rule would take a sentence like (ii) and change it into a sentence like (iii):

ii) The red book bores me.

iii) The red book me bores.

Similarly we could allow X-bar theory to generate sentences where the work "snookums" appears after every word, then have a transformation that deletes all instances of "snookums" (iv). (v) shows the D-structure of such a sentence. (vi) would be the S-structure (output) of the rule.

iv) "snookums"  $\Rightarrow \emptyset$

v) I snookums built snookums the snookums house snookums.

vi) I built the house.

These are crazy rules. No language has a rule of these types. However, in principle, there is no reason that rules of this kind couldn't exist. We thus need to restrict the power of transformational rules. We do this two ways:

vii) *Rules must have a motivation.* Frequently these motivations are output constraints, like the EPP that we saw in the last chapter, or morphophonological, like the ones we will propose in this chapter.

viii) Not only are rules motivated by output constraints, they are restricted by them. *You cannot write a rule that will create a violation of an output constraint.*

As we go along we will consider specific ways to constrain transformational rules so that they don't overgenerate.

## 1. VERB MOVEMENT (V → T)

### 1.1 French

Let's return now to the problems we raised in the introduction to this chapter. Let's start with the sentence from French:

4) Je mange souvent des pommes.  
I eat often of.the apples  
"I often eat apples."

In this sentence, an adjunct surprisingly appears between the head of VP and its complement. Compare this sentence to the English sentence in (5):

5) I often eat apples.

In the English sentence, the adjunct does not intervene between the verb and the complement. The tree for (5) would look like (6).

6)

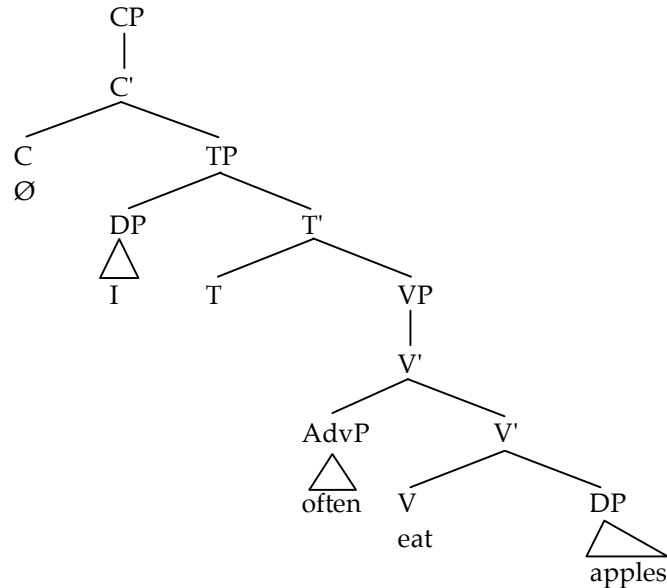

Notice the following thing about this structure. There is a head position that intervenes between the subject DP and the adverb *often*: this is the T position. T, you will recall, gives its inflection to the verb or surfaces as an auxiliary. Notice that in French (4), the thing that appears between the subject and the adverb is not T, but the tensed main verb.

Keeping this idea in the back of your mind now consider the following chart, which shows the relative placement of the major constituents of a French sentence with a tensed main verb (b), and English sentence with a tensed verb (a), and both languages with auxiliary constructions (c and d):

7)

a)	I	T	often	eat	apples
b)	Je	mange	souvent		des pommes
c)	I	Have	often	eaten	apples
d)	J'	Ai	souvent	mangé	des pommes

There are several things to observe about this chart. Recall from chapter 2, that auxiliaries are instances of the category T; as such, V' adjuncts are predicted to invariably follow them. This seems to be the case (c and d). What is striking about the above chart is that tensed main verbs in French also seem to occupy this slot, whereas in English, they follow the adverb. How can we account for this alternation? Let's assume that the form which meets X-bar theory (and happens to be identical to the English tree in (6)) is what is generated in *both* French and English. The difference between

the two is that French has a special *extra* rule which moves its verbs out of the VP. More precisely, it moves them into the slot associated with T. This is the transformational rule we will call  $V \rightarrow T$ ; it is also known as *verb movement* or *verb raising*. This rule is informally stated in (8):

8)  $V \rightarrow T$  movement: Move the head V to the head T.

Before looking at an example, consider for a moment why this rule might apply. Much like the rule of affix lowering we introduced for English in chapter 7, this rule exists to get an inflectional affix on the verb. In fact, let's go one step further, let's claim that affix lowering and verb raising are really the same operation. Notice that they are in complementary distribution – a language either has one or the other. The difference between a verb raising language (French) and an affix lowering language (like English) might simply be one of a parameter. All languages have some version of this rule, some set the parameter to raise the verb to T, others set it to lower the T to the V.

9) *Verb movement parameter*: Verbs raise to T or T lowers to V.

This provides a simple account of the difference between English and French adverbial placement.

Now, let's do a derivation for the French sentence *Je mange souvent des pommes*. The first step in the derivation is to build an X-bar structure, and insert all the words. This gives us the D-structure of the sentence:

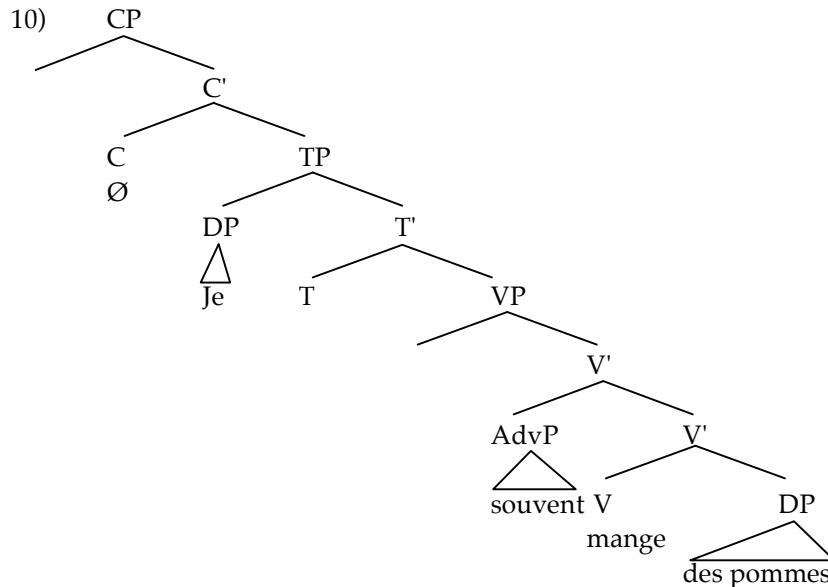

Notice that this D-structure is not a grammatical sentence of French (yet). In fact it has exactly the same word order as the English sentence in (5).

The next step in the derivation is to apply the transformation of Verb Movement. One typical way of representing a movement transformation is to draw a tree with an arrow.

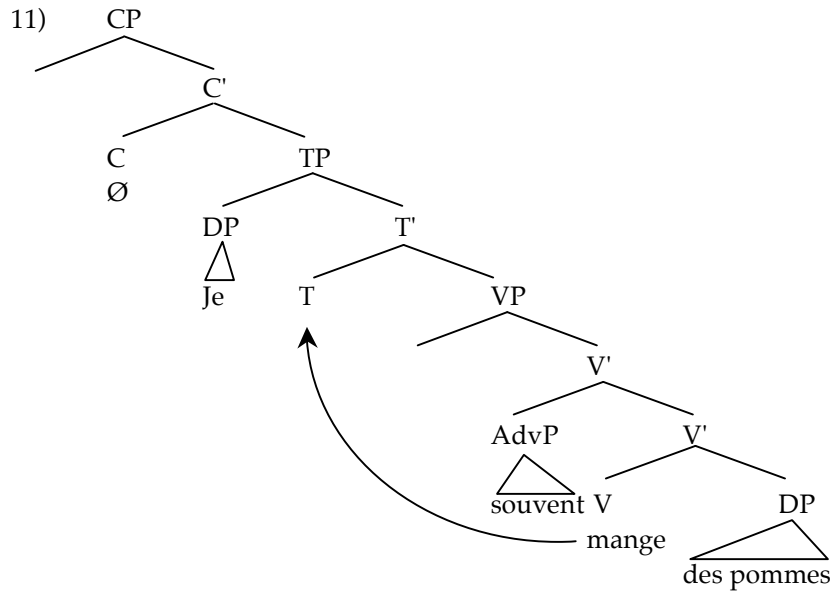

This results in the correct S-structure string:

12) Je mange<sub>i</sub> souvent *t<sub>i</sub>* des pommes.

Yet at the same time, we can maintain X-bar theory. The *t<sub>i</sub>* here stands for “trace” and sits at the D-structure position of the verb.

Consider now the related derivation for the English sentence *He often eats apples*. The D-structure is the same, except with English words:

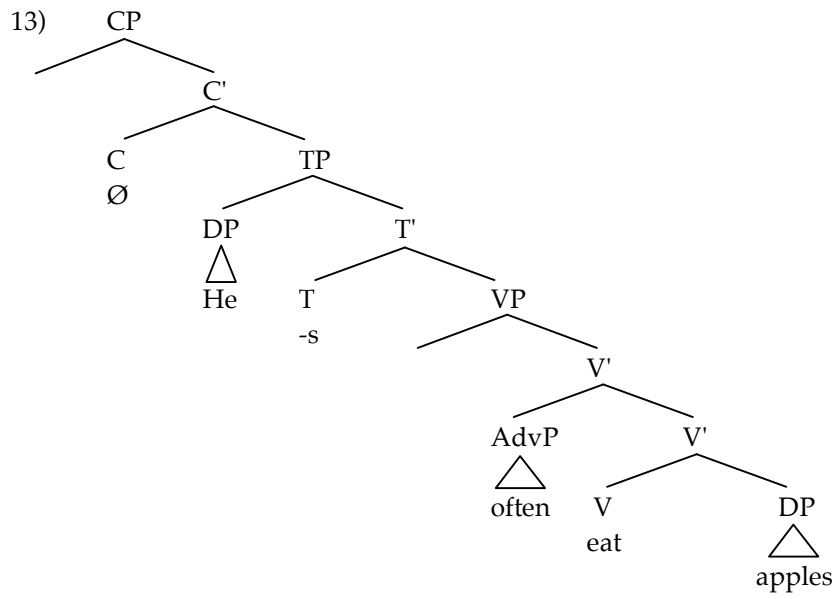

Since English is parameterized for affix lowering rather than verb raising, the inverse movement to French applies:

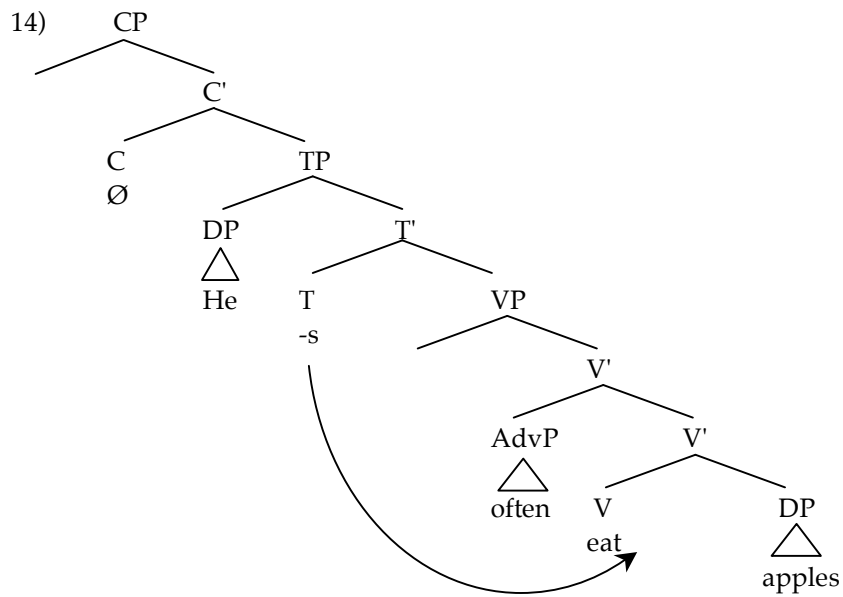

This results in the grammatical S-Structure:

15) He often eats apples.

What we have seen so far is a rather technical solution to a relatively small problem. Now, I'm going to show you that this solution can be extended. Recall our chart with adverb above in (7). Consider now the identical chart with negatives:

16)

a)	I	do	not	eat	Apples
b)	Je	ne-mange	pas		des pommes
c)	I	have	not	eaten	Apples
d)	Je	n'ai	pas	mangé	des pommes

Ignore for the moment the French morpheme *ne-*, which is optional in spoken French in any case. Concentrate instead on the relative positioning of the negatives *pas* and *not* and the verbs. The situation is the same as with the adverb *often*. All auxiliaries in both languages precede negation, as does the main verb in French. But in English, the main verb follows the negation.<sup>1</sup>

We can apply the same solution to this word order alternation that we did for adverbs: we will move the verb around the negation. The tree here will be slightly different, however. Let us assume that *not* heads a projection called NegP, and this projection is the complement of TP, and dominates VP.

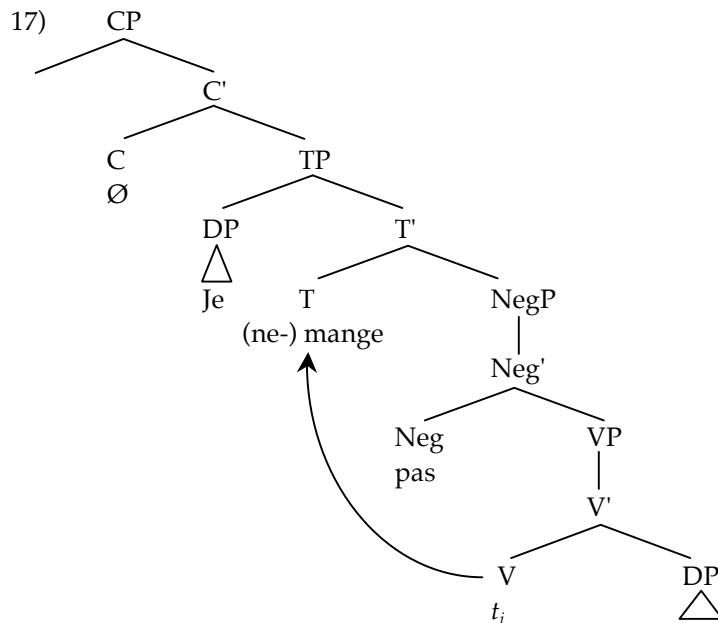

<sup>1</sup> For the moment, ignore the *do* verb. We will return to this below.

The transformation of verb movement then raises the verb around *pas* as represented by the arrow in (17).<sup>2</sup> Again this derives the correct word order.<sup>3</sup>

---

*You now have enough information to try General Problem Sets 1 & 2*

---

Observe that the alternation in position between an auxiliary and a tensed verb is not limited to French. Many (if not most) languages show this same alternation. Take for example the language Vata, a Kru language of West Africa. The underlying word order of Vata is SOV (data from Koopman 1984).

- 18) a) A      la      saka li.  
           we    have   rice eaten  
           "We have eaten rice."
- b) A      li      saka.  
           we    eat    rice  
           "We eat rice."

In the sentence with the overt auxiliary, the verb appears to the far right. When there is no auxiliary, the verb appears in the structural slot otherwise occupied by the auxiliary. This alternation can be attributed to verb raising. When there is an auxiliary (*la*), T does not require "support" from the verb, so the verb remains in its base generated position (19).

---

<sup>2</sup> An alternative to this is often found in the literature. In this alternative *ne-* heads the NegP and *pas* is in the specifier of NegP. The verb raises and stops off at the Neg head, (picking up *ne-* on the way) and then moves up to T. This alternative was presented in Pollock (1989).

<sup>3</sup> You might note that in English the comparable operation (affix lowering) does not apply around negation. We explore this issue in more detail below.

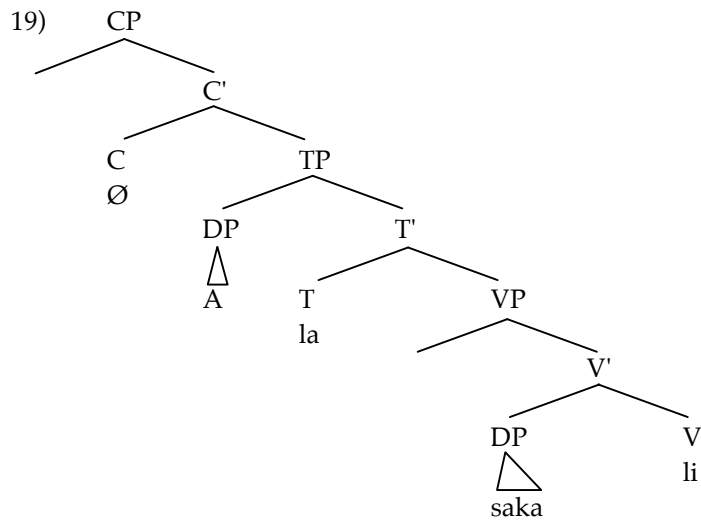

When there is no auxiliary, T requires support, and the verb raises around the object to T:

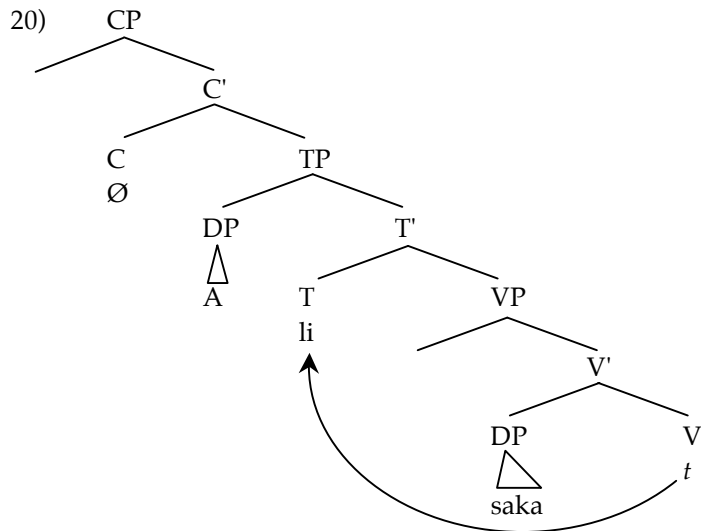

This, of course, is the correct word order (*A li saka*).

The transformational rule of  $V \rightarrow T$  movement thus provides a simple, elegant and motivated account of cases where the verb shows up in the “wrong” position. The motivation for the verb to move (or the affix to lower) is intuitive: the need for the verb to get its inflection. This seems to correlate with the fact that in many languages there are positional alternations where auxiliaries (T) and tensed verbs alternate and are in

complementary distribution. This also gives a straightforward account of certain cross-linguistic differences. We can account for the fact that English and French consistently differ in the relative placement of adverbs and negation with respect to tensed verbs. We derived this difference by appealing to a parameter which either has the verb raise to T, or T-affixes lower to the verb.

### 1.2 Irish

Now we'll turn to the other (more difficult) problem raised in the introduction to this chapter. This is the Verb-Subject-Object (VSO) order of Irish.

- 21) Phóg Máire an leprechaún.  
 Kissed Mary the leprechaun  
 "Mary kissed the leprechaun."

As we observed above, there is no way that X-bar theory can generate a sentence of this type. This is true of every basic sentence in Irish. VSO order is found in every tensed sentence in Irish. It is also the basic order of about 9 percent of the world's languages, including languages from many different language families such as Tagalog, Welsh, Arabic, Mixtec, Mayan, Salish, Turkana, Maasai (to name only a few).

#### Digression on Flat Structure

Up until the early 1980s, most linguists considered VSO languages to simply be exceptions to X-bar theory. They proposed that these languages had a **flat structure**:

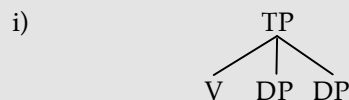

This structure is called "flat" because there are no hierarchical differences between the subject, the object, and the verb. In other words, there are no structural distinctions between complements, adjuncts and specifiers. These sentences don't have a VP constituent. In (i) there is no single node dominating both the V and the second DP, but excluding the subject DP.

There is a delicate balance between a theory that is empirically adequate (one that accounts for all the data), like a theory that has *both* flat structure languages and X-bar languages, and one, which is explanatorily adequate and elegant (like pure X-bar theory). By claiming that these languages were exceptions, linguists were left with a considerably less elegant theory. Thus the race was on to see if there

was some way to incorporate these languages into X-bar theory. Notice, however, that pure elegance alone is not sufficient cause to abandon an empirically adequate but inelegant theory like flat structure – we must also have empirical evidence (data) in favor of the elegant theory.

Flat structure makes the following predications:

- a) There is no VP constituent.
- b) There is no evidence for a hierarchical distinction between subjects and objects – they both have the same mother and mutually c-command one another.

It turns out that both these predications are wrong. First, if VSO languages have no VP in simple tensed clauses they should have no VPs in other clause types either. McCloskey (1983) observed for Irish, and Sproat (1985) for Welsh, that this is false.

- ii) Tá Máire [ag-pógail an lucharachán].  
Is Mary ing-kiss the leprechaun  
“Mary is kissing the leprechaun.”

In auxiliary sentences in Irish, there is a plausible candidate for a VP: the words bracketed in (ii). If this V + O sequence is a constituent, it should obey constituency tests. Two typical constituency tests from chapter 3, coordination and movement (clefting), show this:

- iii) Tá Máire [ag-pógail an lucharachán] agus [ag-goidú a ór].  
Is Mary [ing-kiss the leprechaun] and [ing-steal his gold]  
“Mary is kissing the leprechaun and stealing his gold.”
- iv) Is [ag-pógáil an lucharachán] atá Máire.  
It-is [ing-kiss the leprechaun] that.be Mary  
“It’s kissing the leprechaun that Mary is.”

These sentences show that the bracketed [V + O] sequence in (ii) is indeed a constituent, and a plausible VP.

Now, turn to the second prediction made by flat structure, where all the DPs are on a par hierarchically. This too we can show is false. Recall from chapter 5, that there is at least one phenomenon sensitive to hierarchical position: the distribution of anaphors. Recall that the antecedent of an anaphor must c-command it. If flat structure is correct, then you should be able to have either DP be the antecedent and either DP be the anaphor, since they mutually c-command one another (they are sisters):

v)

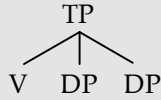

The data in (vi) and (vii) show that this is false. Only the object DP can be an anaphor. This means that the object must be c-commanded by the subject. Further it shows that the subject cannot be c-commanded by the object. Flat structure simply can't account for this.

vi) Chonaic Síle<sub>i</sub> í-fein<sub>i</sub>.  
 Saw Sheila her-self  
 "Sheila saw herself."

vii) \*Chonaic í-fein<sub>i</sub> Síle<sub>i</sub>.  
 Saw her-self Sheila  
 "Sheila saw herself."

The flat structure approach, if you'll pardon the pun, comes up flat. It makes the wrong predictions. The verb raising approach proposed in the main text doesn't suffer from these problems. It maintains X-bar theory so both has a VP and a hierarchical distinction between subjects and objects.

---

*You now have enough information to try General Problem Set 3*

---

The failure of X-bar theory to account for 9 percent of the world's languages is a significant one! However, the theory of transformations gives us an easy out to this problem. If we assume that VSO languages are underlyingly SVO (at D-structure), then a transformational rule applies which derives the initial order.

## 22) SVO $\Rightarrow$ VSO

How might we actually structurally implement this rule? Given the discussion in section 1.1 above, the answer should be obvious: we can use verb movement.

There is some straightforward evidence in favor of a verb movement approach to Irish word order: First, we see the same type of positional auxiliary/tensed verb word order alternations.

23) Tá Máire ag-pógáil an lucharachán.  
 Is Mary ing-kiss the leprechaun  
 "Mary is kissing the leprechaun."

- 24) Phóg Máire an lucharachán.  
 kissed Mary the leprechaun  
 "Mary kissed the leprechaun."

As in the French and Vata cases, with respect to a certain position (in Irish the initial position), auxiliaries and main verbs are in complementary distribution – evidence for  $V \rightarrow T$  movement.

Unfortunately the situation here is not as straightforward as the French and Vata cases. If we try to draw the tree for (24) we immediately run into a problem.

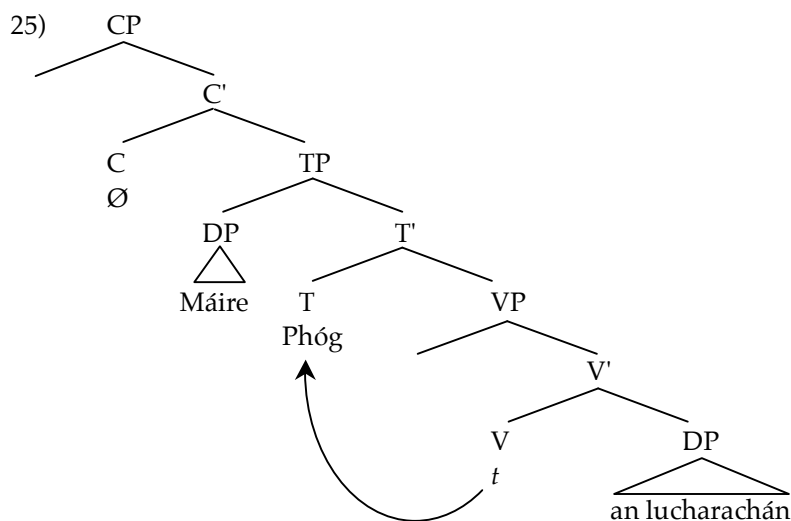

While moving the verb to T certainly accounts for the alternation between verbs and auxiliaries, it does not derive the correct VSO word order. Instead we get incorrect SVO order.

In all the sentences of Irish we've looked at, T (in the form either of an auxiliary or a raised tensed verb) seems to precede its specifier (the subject). One possibility to resolve this might be in exercising the parameters we looked at in chapter 6. So we might try putting the specifier of TP to the right in Irish:

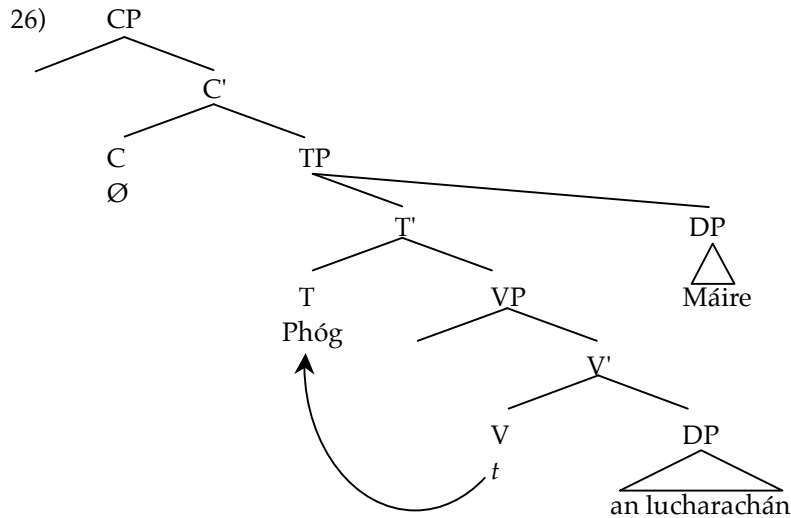

But this doesn't work, if you look carefully at the order of elements in 26 you'll see this results in VOS order, which is completely ungrammatical in Irish:

- 27) \*Phóg an lucharachán Máire.  
 kissed the leprechaun Mary  
 (ungrammatical with the reading "Mary kissed the leprechaun.")

So X-bar parameters clearly aren't the solution. The only alternative is to claim that we've been generating subjects in the wrong position. That is, subjects are not generated in the specifier of TP, like we have been assuming. Instead, they are *underlyingly* generated in the specifier of VP.

The idea that subjects are generated in the specifier of VP is called the *VP-internal subject hypothesis*, and was first proposed by Hilda Koopman and Dominique Sportiche (1991). The idea has some thematic motivation. By assuming that subjects are generated inside the VP we can make the strong claim that theta roles are assigned entirely within the VP. We can encode this in the following constraint:

28) *The Locality Constraint on Theta Role Assignment*

Theta roles are assigned within the projection of the head that assigns them (i.e., the VP or other predicate).

If we assume the VP-internal subject hypothesis, the derivation of VSO order is trivial: It involves a straightforward instance of  $V \rightarrow T$  movement:

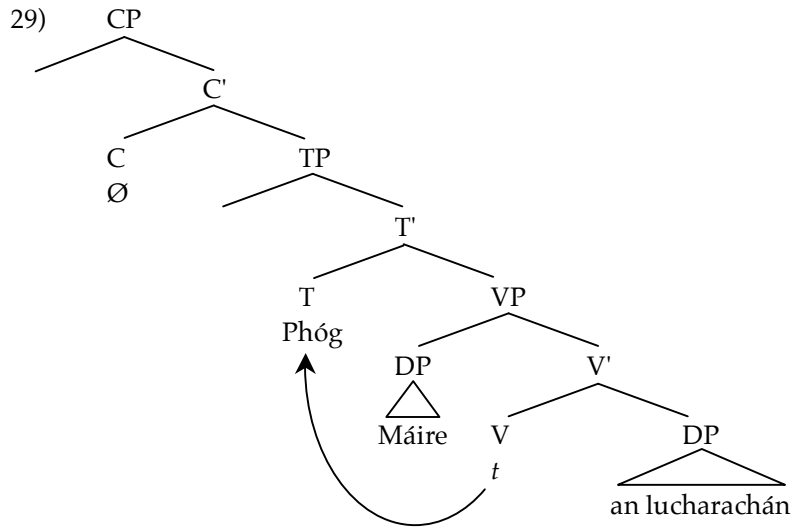

This derives the correct VSO order of Irish.

Now at this point your head is probably spinning and you are saying to yourself “Hold on, what about English, French, and Vata! In all those languages the subject precedes T.” Alas, this is true. The solution to the conundrum lies easily within our grasp, however. Perhaps it is the case that in English, French, and Vata (but not the VSO languages) subject DPs *move* from the specifier of VP to the specifier of TP. A simple French sentence then would have two movements: one for the verb, one for the subject.

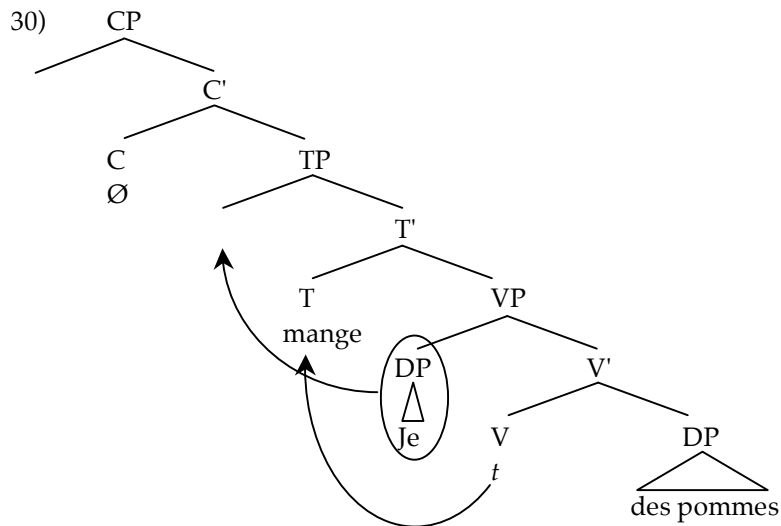

This second kind of movement is called *DP movement* and is the topic of the next chapter, where we'll discuss further evidence for VP-internal subjects. The correct formulation and motivations for DP movement are set out there. For now, we'll just observe that we have not argued ourselves into a corner; there is a way out.

---

*You now have enough information to try General Problem Sets 4 & 5 and Challenge Problem Set 1*

---

Let us summarize the (quite complicated) discussion up to now. In section 0, we saw that there are instances where X-bar rules fail to generate the correct orders of sentences. To solve this problem, we looked at a new rule type: the transformation. Transformations take a structure generated by X-bar theory and change it in restricted ways. We've looked at one such transformation:  $V \rightarrow T$ . This rule has the function of movement a verb to the T head. It does so in order that the verb can support inflection. We also looked at the mirror image of verb movement: affix lowering, which lowers an inflectional suffix to the verb. These are in complementary distribution, so serve as tokens of the same rule. A language is parameterized as to whether it takes the raising or the lowering variant. The difference in word order between French and English negatives and sentences with adverbials can be boiled down to this parameter. The rule of verb movement itself can explain the fact that an adjunct (the adverb) appears between a head and its complement. Taken together with the VP-internal subject hypothesis, verb movement can also explain the very problematic basic VSO word order. This simple straightforward tool thus allows us to account for a very wide range of complicated facts.

## 2. T MOVEMENT ( $T \rightarrow C$ )

Before leaving the topic of the movement of heads, we briefly return to a phenomenon somewhat obliquely discussed in chapter 7. This is the phenomenon known as  $T \rightarrow C$  movement or subject-aux inversion. In yes/no questions in English (questions that can be answered with either a *yes* or *no*), auxiliary verbs invert with their subject:

- 31) a) You *have* squeezed the toilet paper.  
       b) *Have* you squeezed the toilet paper?

In chapter 7, we claimed that this alternation is due to the presence of a special null question complementizer  $\emptyset_{[+Q]}$ . We observed that in many languages (such as Polish and Irish) yes/no questions aren't indicated with

subject-aux inversion, but with a special form of the initial complementizer (recall Irish is VSO to start with, so subject-aux inversion would do nothing):

32) An bhfaca tú an madra?

Q See you the dog

“Did you see the dog?”

We claimed that subject-aux inversion is a special case of these question complementizers. English doesn't have an overt (pronounced) question complementizer like the Irish *an*. Instead, English has a null  $\emptyset_{[+Q]}$  complementizer. Being phonologically null, however, is a bit of a problem, since the difference in meaning between a statement and a question is encoded in something you can't hear. English employs a mechanism (which we now know is a transformation), that gives phonological content to that  $\emptyset_{[+Q]}$  by moving T to it, *around the subject*:

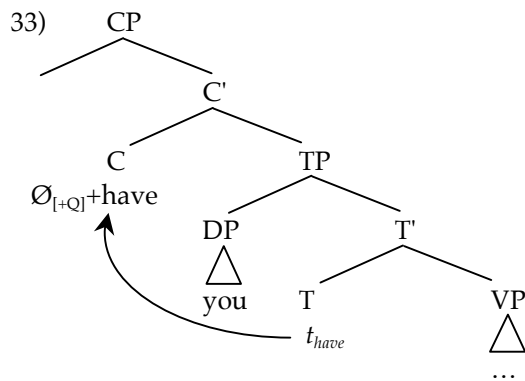

This kind of analysis is supported by the fact subject-aux inversion ( $T \rightarrow C$ ) is in strict complementary distribution with overt question complementizers as seen in the following embedded clauses:

- 34) a) I asked *have* you squeezed the toilet paper.<sup>4</sup>  
 b) I asked whether you *have* squeezed the toilet paper.  
 c) \*I asked whether *have* you squeezed the toilet paper.

<sup>4</sup> For many people this sentence is not grammatical unless the embedded clause is a direct quote. (That is, it would properly be written with “ ” around it.) This fact muddies the waters somewhat in this argument, as it may not be the case that  $T \rightarrow C$  movement is allowed at all in embedded clauses in English. However, the same facts do hold true in other languages where subject-aux inversion in embedded clauses is more clearly instantiated.

So the process of subject-aux inversion must be a property triggered by complementizers. This rule is very similar to the rule of  $V \rightarrow T$  movement. It is triggered by morphophonological requirements (such as the fact that something contentful must be pronounced, or that an affix needs a host). Both movements are instances of moving one head into another, so are considered instances of the same basic operation: *head-to-head movement*. This is a cover term for both  $V \rightarrow T$  and  $T \rightarrow C$ .

#### VSO as Raising to C?

In the previous section we claimed that Irish VSO order involves raising the verb to T. We were also forced to claim that subjects were generated VP internally. Notice that in English, we also have a VS order, found in yes/no questions. These VS orders we analyze as  $T \rightarrow C$  movement, with the subject remaining in its more typical place in the specifier of TP. Why don't we analyze Irish VSO order the same way? Instead of having VP-internal subjects, why don't we simply have verbs raise to T, then do  $T \rightarrow C$  in *all* Irish clauses. This too would derive VSO order. There is a very good reason for this. Recall that in English  $T \rightarrow C$  movement is blocked when there is an overt complementizer. (You don't move T into the C, because it already has phonological content.) If Irish VSO really involves raising to C, then it should be the case that you do *not* get VSO order when there is an overt complementizer. This is false. You get VSO order even when there is a complementizer.

- i) Dúirt mé gur *phóg* **Máire** an lucharachán.  
Said I that kissed Mary the leprechaun  
"I said that Mary kissed the leprechaun."

This means that VSO must result from movement of the verb to some position lower than the complementizer. This is the analysis we argued for above, where V raises to T, and the subject is in the specifier of VP.

It appears as if  $V \rightarrow T$  and  $T \rightarrow C$  interact. In English, only auxiliaries ever occupy the T head as free-standing entities. Main verbs do not raise to T in English. So only auxiliaries undergo  $T \rightarrow C$  movement. Main verbs never do:

- 35) a) Have you squeezed the toilet paper?  
b) \*Squeezed you the toilet paper?

Contrast this to French. In French, main verbs undergo  $V \rightarrow T$  movement. This means that when French does  $T \rightarrow C$  movement, main verbs

are predicted to also invert (because they are in T). This can be seen in the following tree:

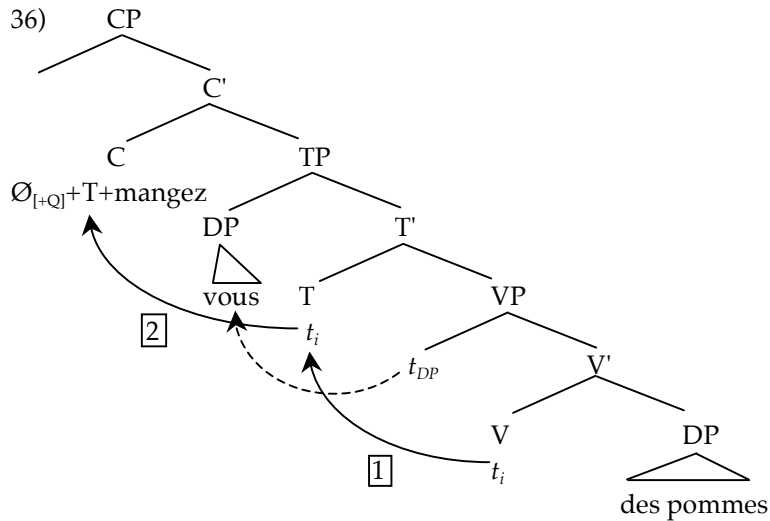

Movement [1] is  $V \rightarrow T$  movement. Movement [2] is subsequent movement of the verb (in T) to C as part of  $T \rightarrow C$  movement.

This prediction is borne out. Main verbs in French do invert in questions, but English main verbs do not.

- 37) a) Mangez-vous des pommes?  
b) \*Eat you the apples?

To summarize, we have looked (again) at the transformation of  $T \rightarrow C$  movement in more detail. We saw that it has a phonological motivation, and is similar in some ways to  $V \rightarrow T$  movement. We also noticed that in a language (such as French) where  $V \rightarrow T$  movement applies main verbs as well as auxiliary verbs undergo  $T \rightarrow C$ .

---

*You now have enough information to try General Problem Sets 6, 7 & 8 and  
Challenge Problem Sets 2, 3, 4 & 5*

---

### 3. DO-SUPPORT

In English, an interesting effect emerges when we try to question a sentence with no auxiliary:

- 38) a) You eat apples.  
b) Do you eat apples?

In sentences with no auxiliary, we insert a dummy (=meaningless) auxiliary in yes/no questions. There must be a reason for this. We have argued that in English, T lowers to attach to V, at the same time in questions, the transformation of T → C movement forces the same T to raise. This is a contradiction: we want T to raise and lower at the same time. The phenomenon of *do*-support appears to be an escape hatch for T. If we insert a dummy (contentless) auxiliary to support the inflectional affixes, then this dummy can undergo T → C movement. This is an insertion transformation. This transformation is called **do-insertion** or **do-support**:

39) *Do-insertion*: When there is no other option for supporting inflectional affixes, insert the dummy verb *do* into T.

What triggers this transformation is different than what triggers the movement transformations. The movement transformations are motivated (triggered) by morphophonological concerns. Insertion transformations apply only in the case that there is nothing else you can do. They are, in essence, operations of *last resort*, you only apply them when you absolutely have to and when no movement transformation can apply.

#### **There are Two Verbs *Do* in English**

Quite confusingly, English has two verbs *to do*. One is a main verb, meaning roughly “accomplish something,” “perform an action.” The other is a dummy (meaningless) auxiliary, which is inserted under “*do*-support.” These are quite distinct entities. As can be seen by the fact that you can have both of them in one sentence:

i) Did you do your homework?

Main verb *do* is not an auxiliary and is not in T, this can be seen by the fact that it cannot undergo T → C movement, and it follows *often* and *not*.

ii) \*Do you your homework?

iii) You often do your homework.

iv) You have not done your homework.

When invoking the *do*-insertion transformation, be careful that you only do it when dummy *do* is involved – not main verb *do*.

*Do*-support doesn't apply only in questions; it also shows up in negative sentences.

40) a) I ate the apple.

b) I didn't eat the apple.

The negative morpheme *not* blocks the operation of affix lowering. The reasons for this are obscure. We will simply state it here as a stipulation.

#### 4. MULTIPLE AUXILIARIES AND AFFIX-HOPPING IN ENGLISH

##### 4.1 Multiple Auxiliaries

One issue still remaining in our discussion comes from the behavior of sentences in English with more than one auxiliary. Take the following sentence as an example:

41) Shannon should have been being fed at the table.

The placement of *should* is easy, it's in T, but where should the other auxiliaries in this sentence go? In chapter 7, challenge problem set 3, we suggested that one solution to this problem might be to treat auxiliaries as Vs that take other VPs as complements.

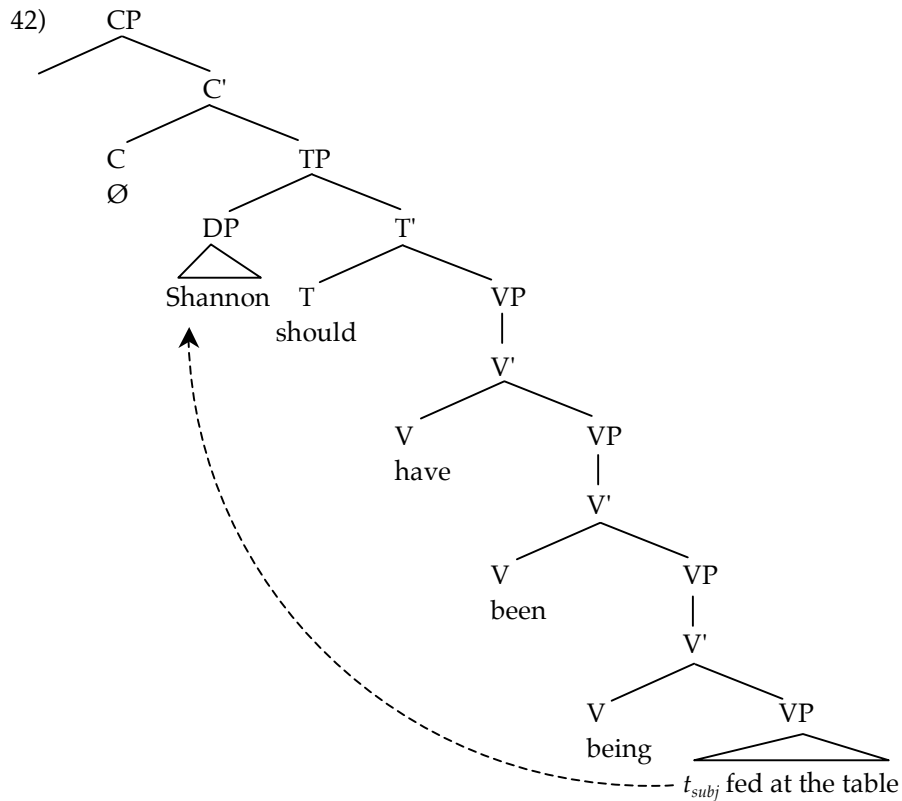

One piece of evidence for this approach is that these auxiliaries can follow negation and adverbs:

- 43) a) Shannon should not have been being fed at the table.  
 b) Shannon should [<sub>Adv</sub> never] have been being fed at the table.

Notice that negation cannot precede modals (which we will continue to treat as belonging to category T):

- 44) a) \*Shannon not should have been being fed at the table.  
 b) \*Shannon did not should have been being fed at the table.

This shows that these auxiliaries are not in T.

With this then, we have argued ourselves into a corner, since there are many instances where the auxiliary verbs *be* and *have* do appear to be in T because they precede negation:

- 45) a) Shannon *has* not eaten.  
 b) Shannon *is* not eating.

There is a simple solution to this, auxiliary verbs (but not main verbs) raise in English. This means that the verb movement parameter needs to be modified:

- 46) *Verb Movement Parameter*: Option 1: All tensed verbs raise to T; Option 2: tensed Auxiliaries raise to T and T lowers to tensed main verbs.

English chooses the second option.

Let's tree a number of sentences and see how this might work. Let's start with a simple sentence with a modal verb. We're continuing to treat modals as instances of the category T:

- 47) Shannon should eat.

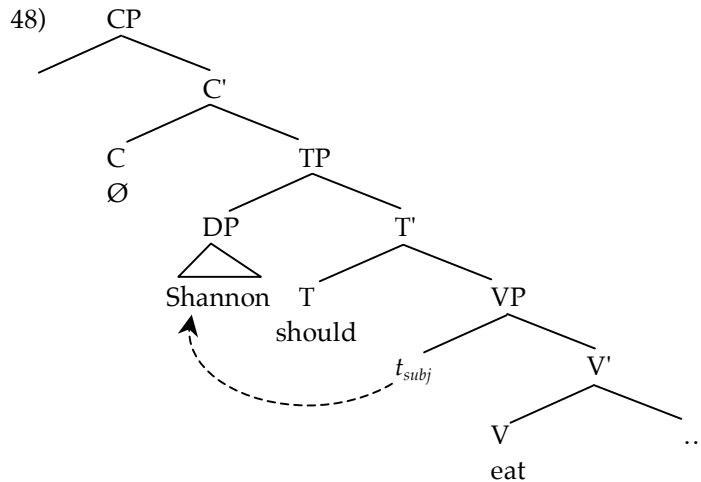

There is no verb movement in this sentence, the only movement is the shift of the subject DP from the specifier of the VP into the specifier of TP. Next let's contrast this with a sentence with a tense suffix and no auxiliary at all:

49) Shannon ate.

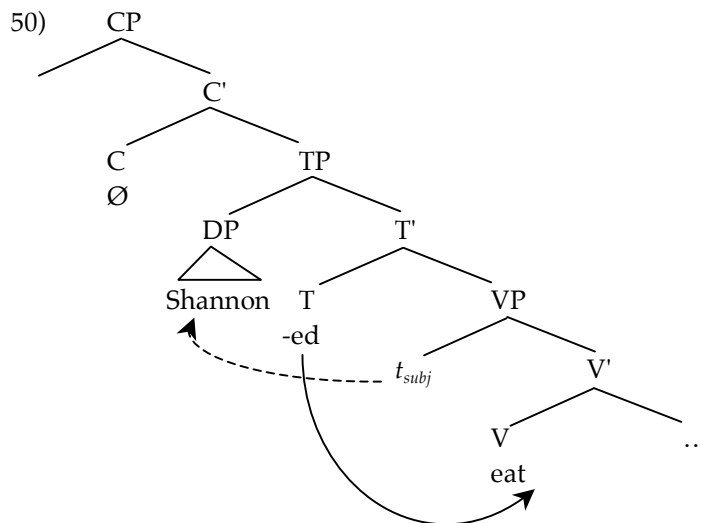

Here the *-ed* suffix lowers and attaches to the verb (this is followed by a morphological rule that turns *eat-ed* into *ate*). Finally here's the tree for a sentence with an auxiliary:

51) Shannon has eaten.

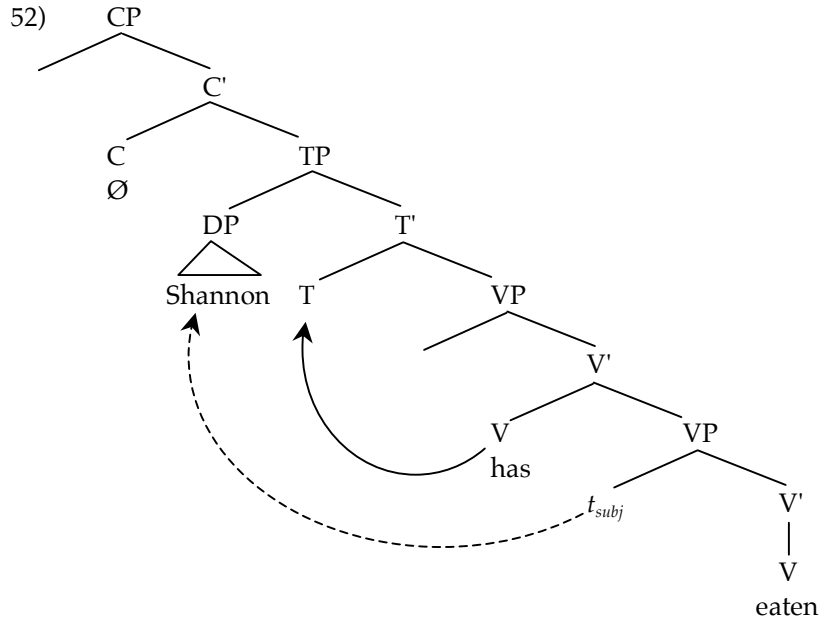

Here, because there is no modal in T and no suffix in T, the auxiliary *have* raises to T.

#### 4.2 Affix-hopping

This analysis of multiple auxiliary constructions brings to light another property of English. Consider the shape of the verb that follows each of most common usages of the auxiliaries. When a verb follows a modal (category T with no lowering), it takes the same form as it would in a non-finite context (i.e., after *to*). We call this form the **base** form.

53) Shannon should *eat*. (cf. I want to *eat*.) *modal*

When the verb follows the auxiliary *have* in its perfective usage (that is, when it marks that an event has a clear end-point), then the verb must appear in its **past participle** form. This is usually marked with the *-en* or *-ed* suffix, although there are many verbs that have irregular participial forms. Be careful not to mix up the *-ed* suffix here with the past tense suffix; they are homophonous but they mean different things. To avoid this confusion we will indicate the past participle with *-en*.

54) Shannon has eaten. *perfective*

When the verb is indication that the action has a portion that is on-going, we use the *progressive* form (this is sometimes also called a gerund, and the aspect is sometimes called imperfect).

55) Shannon is eating. *progressive*

Finally, we have the form of the verb that is used for the passive voice. We'll look at the passive in more detail in later in chapter 10. Like the perfective, the passive uses the past participle, but follows the verb *be*:

56) The bread was eaten. *passive*

For each English type of inflection, we have a distinct set of verbal forms. The suffix on the verb and the auxiliary together determine the meaning of the expression. When we have a tensed main verb (that is, a simple past or simple present), then the verb bears the appropriate tense morphology (-s, -d, or -Ø). When a modal (category T) such as *can* or *will* appears, then there is no morphology on the verb. When you have a perfective structure, we pair the auxiliary *have* with an -en participle. The progressive is a pairing of the verb *be* with an -ing progressive form. Finally the passive is a pairing of the verb *be* with an -en participle. This is summarized in the following chart.

57) a) Simple Past and Present	V+ed/ V+s/ V+Ø
b) Modal	modal V
c) Perfective	have V+en
d) Progressive	be V+ing
e) Passive	be V+en

Notice what happens when we combine these patterns, the information about aspect and voice gets distributed in a systematic way:

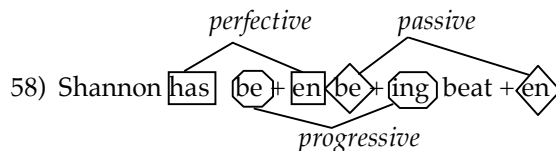

We have a pattern of interleaving here, where the suffix associated with each verbal inflection is actually one verb or auxiliary down from the auxiliary that is associated with it. Chomsky, in what is perhaps his most famous book, (*Syntactic Structures* 1957) provided an account of this phenomenon known as Affix-hopping. The analysis we provide here, in terms of the affix lowering transformation we already have, is a modified version of Chomsky's.

Observe that the meaning “passive” cannot be described by the verb *be* alone, since *be* is found in both passives and progressives, and it cannot be described by just the suffix *-en*, since that is associated with both passives and perfectives. The notion of “passive” is only encoded when both the *be* and the *-en* suffix are present. Conversely, the meaning of *be* in isolation isn’t clear as it can be found with multiple inflection types. One way of accounting for this is by having special lexical items that are syntactically decomposable (that is, they can be split into two different syntactic units). We can encode these as follows:

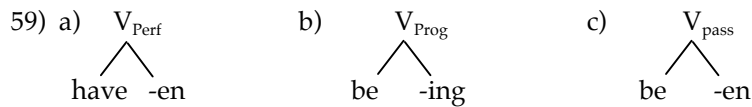

Of course using these lexical items would result in the wrong word order. Chomsky’s insight was that this contradiction could be resolved using a transformation: affix lowering (in combination with  $V \rightarrow T$  movement). Let’s start with a simple perfective sentence.

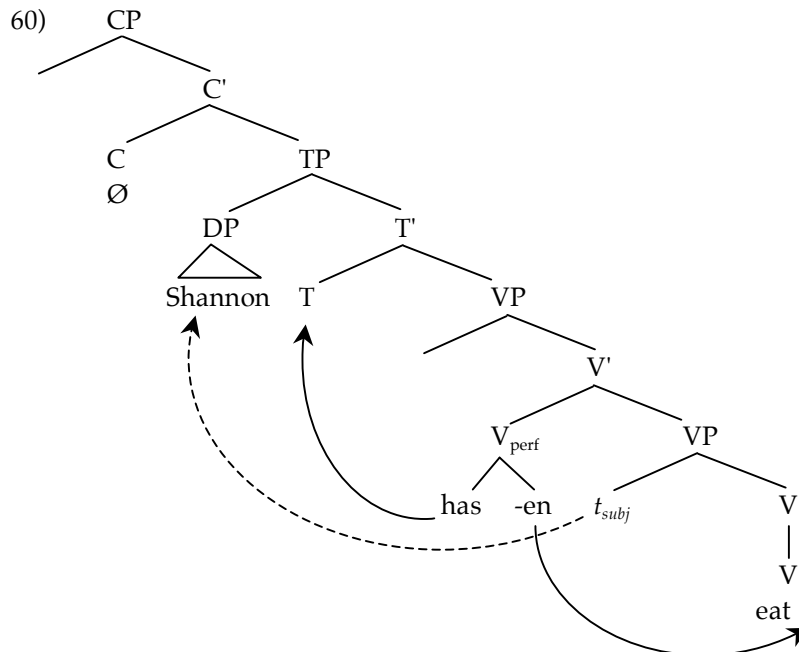

In this tree, we have both verb (auxiliary) raising and affix lowering. The derivation of simple progressives and passive verb morphology is the same substituting *be+ing* and *be+en* in for the higher V. A more complicated example in (61):

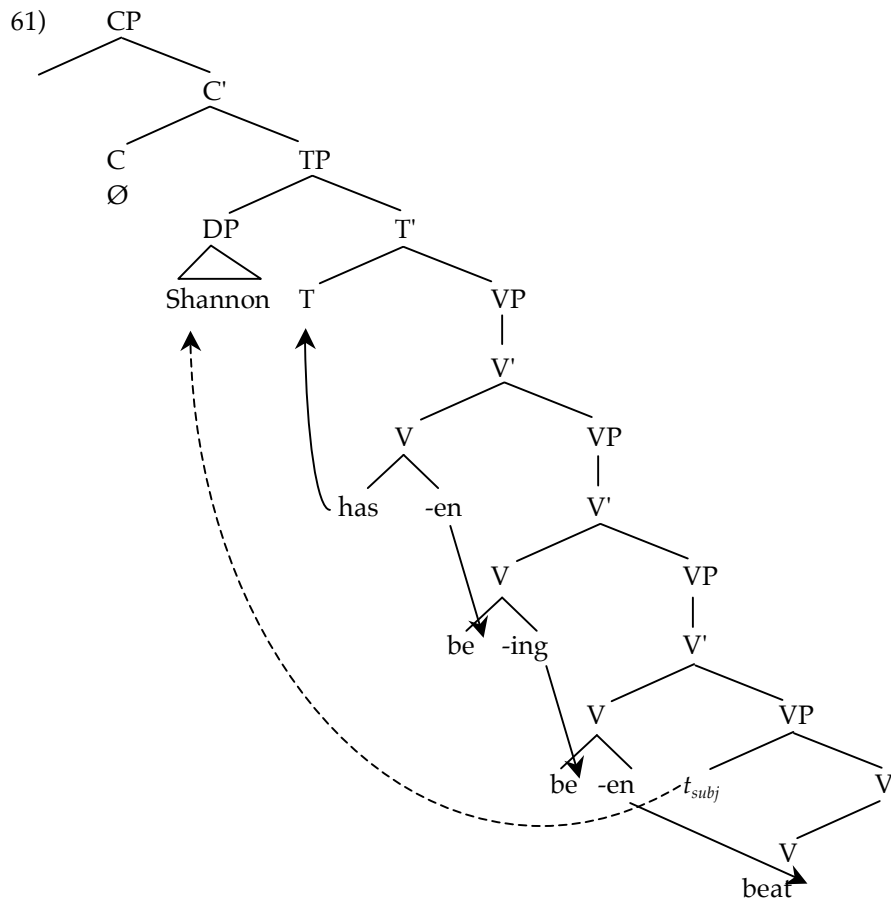

There are some things about these derivations which are still mysterious of course, For example, why lexical items that can be split this way exist and the precise motivation for the lowering the affixes (when they could, in principle, attach to the auxiliary they come with). Nevertheless this seems like a a good first approximation at capturing the complex behavior of English auxiliaries.

---

*You now have enough information to try General Problem Set 9*

---

## 5. SUMMARY

In this chapter we've looked at a range of phenomena (subject-aux inversion, word order differences among languages, and *do*-support) that support the basic notion that we need more than X-bar rules. We have introduced

the transformational movement rules of  $V \rightarrow T$  and  $T \rightarrow C$  and the insertion rule of *do*-support to account for these phenomena.

### APPENDIX: TESTS FOR DETERMINING IF A LANGUAGE HAS $V \rightarrow T$ OR AFFIX LOWERING

The following are tests that you can use to determine if a particular language shows verb raising or not. These tests work well on SVO languages, but don't work with SOV languages (such as Japanese).

- A) If the language shows Subj V *often* O order then it has  $V \rightarrow T$ .  
If the language shows Subj *often* V O order then it has affix lowering.
- B) If the language shows Subj V *not* O order then it has  $V \rightarrow T$ .  
If the language shows Subj *not* V O order then it has affix lowering.
- C) If main verbs undergo  $T \rightarrow C$  movement, then the language has  $V \rightarrow T$ .

### IDEAS, RULES, AND CONSTRAINTS INTRODUCED IN THIS CHAPTER

- i) **Transformation:** A rule that takes an X-bar generated structure and changes it in restricted ways.
- ii) **D-structure:** The level of the derivation created by the base, and has had no transformations applied to it.
- iii) **S-structure:** The output of transformations. What you say.
- iv)  **$V \rightarrow T$  movement:** Move the head V to the head T (motivated by morphology).
- v) **Verb Movement Parameter:** Option 1: all tensed verbs raise to T; Option 2: tensed auxiliaries raise to T and T lowers to tensed main verbs.
- vi) **The VP-internal Subject Hypothesis:** Subjects are generated in the specifier of VP.
- vii) **The Locality Constraint on Theta Role Assignment:** Theta roles are assigned within the projection of the head that assigns them (i.e., the VP or other predicate).

- viii) *T* → *C* **Movement**: Move *T* to *C*, when there is a phonologically empty  $\emptyset_{[+Q]}$  complementizer.
- ix) **Do-insertion (Do-support)**: When there is no other option for supporting inflectional affixes, insert the dummy verb *do* into *T*.
- x) **Stipulation**: Affix lowering is *blocked* by the presence of *not* in English.
- xi) **The Model**:

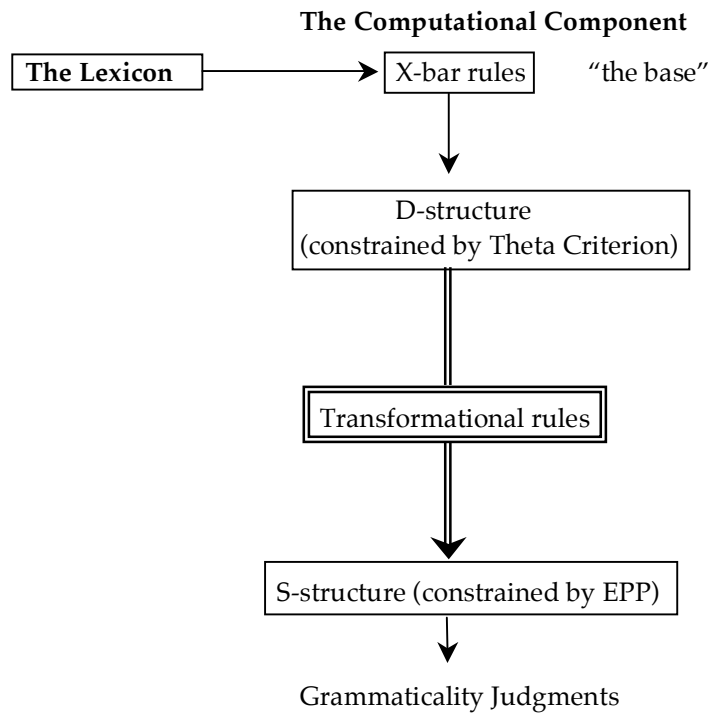

---

### FURTHER READING

- Carnie, Andrew and Eithne Guilfoyle (2000) *The Syntax of Verb Initial Languages*. Oxford: Oxford University Press.
- Emonds, Joseph (1980) Word order in Generative Grammar. *Journal of Linguistic Research* 1, 33–54.
- Koopman, Hilda (1984) *The Syntax of Verbs: From Verb Movement Rules in the Kru Languages to Universal Grammar*. Dordrecht: Foris.
- Koopman, Hilda and Dominique Sportiche (1991) The position of subjects. *Lingua* 85, 211–58.

- Lightfoot, David and Norbert Hornstein (eds.) (1994) *Verb Movement*. Cambridge: Cambridge University Press.
- McCloskey, James (1983) A VP in a VSO language. In Gerald Gazdar, Geoffrey Pullum, and Ivan Sag (eds.), *Order Concord and Constituency*. Foris, Dordrecht. pp. 9–55.
- McCloskey, James (1991) Clause structure, ellipsis and proper government in Irish. *Lingua* 85, 259–302.
- Ritter, Elizabeth (1988) A head movement approach to construct state noun phrases. *Linguistics* 26, 909–29.

## GENERAL PROBLEM SETS

### 1. ITALIAN

*[Data Analysis; Basic]*

Consider the following data from Italian. Assume *non* is like French *ne* and is irrelevant to the discussion. Concentrate instead on the positioning of the word *più*, ‘anymore.’ (Data from Belletti 1994.)

- a) Gianni non ha più parlato.  
Gianni *non* has anymore spoken  
“Gianni does not speak anymore.”
- b) Gianni non parla più.  
Gianni *non* speaks anymore  
“Gianni speaks no more.”

On the basis of this very limited data, is Italian a verb raising language or an affix lowering language?

### 2. HAITIAN CREOLE VERB PLACEMENT

*[Data Analysis; Basic]*

Consider the following sentences from Haitian Creole. Is Creole a verb raising language or an affix lowering language? Explain your answer. (Data from DeGraff 2005.)

- a) Bouki deja konnen Boukinèt  
Bouki already knows Boukinèt  
“Bouki already knows Boukinet.”
- b) Bouki pa konnen Boukinèt  
Bouki neg knows Boukinèt  
“Bouki doesn’t know Boukinèt.”

**3. FLAT VS. HIERARCHICAL STRUCTURE: BERBER***[Data Analysis; Advanced]*

Consider the following data from Berber. Using your knowledge of binding theory, construct an argument that there is a VP in Berber, even though it is a VSO language. (Hint: When there is a VP, the subject c-commands the object, but when there is no VP, the two NPs asymmetrically c-command each other.) (Data From Choe 1987.)

- a) Yutut            wrba<sub>k</sub>            ixfnns<sub>k</sub>  
      hit            boy-NOM<sub>k</sub>        himself<sub>k</sub>  
      "The boy<sub>k</sub> hit him<sub>k</sub>"
- b) \*yutut            ixfnns<sub>k</sub>            arba<sub>k</sub>  
      hit            himself<sub>k</sub>            boy<sub>k</sub>  
      "himself<sub>k</sub> hit the boy<sub>k</sub>"

**4. WELSH***[Data Analysis; Basic]*

Using the very limited data from Welsh below, construct an argument that Welsh has V to T movement. Do not worry about the alternation in the form of the word for "dragon," it is irrelevant to the answer to the question. (Data from Kroeger 1993.)

- a) Gwelodd    Siôn    ddraig.  
    saw.PAST   John   dragon  
    "John saw a dragon."
- b) Gwnaeth    Siôn    weld    draig.  
    do.PAST    John    seen    dragon.GEN  
    "John saw a dragon."

**5. VP INTERNAL SUBJECTS: PRACTICE***[Application of Skills; Basic]*

Using VP internal subjects, with movement to the specifier of TP where appropriate, and verb movement or affix lowering where appropriate, draw the trees for the following sentences:

- a) Tiffany is not taking her syntax class until next year.  
 b) Christine likes wood furniture with a dark finish.  
 c) Les enfants n'ont pas travaillé. (French)  
    the children have not worked  
    "The children haven't worked."

- d) Les enfants (ne)-travaillent pas. (French)  
 the children work not  
 "The children don't work."

### 6. AMERICAN VS. BRITISH ENGLISH VERB *HAVE*

[Critical Thinking; Basic/Intermediate]

English has two verbs *to have*. One is an auxiliary seen in sentences like (a):

- a) I *have* never seen this movie.

The other indicates possession:

- b) I never *have* a pen when I need it.

You will note from the position of the adverb *never* that the possessive verb *have* is a main verb, whereas the auxiliary *have* is raised to T.

*Part 1:* Consider the following data from American English. How does it support the idea that auxiliary *have* ends up in T, but possessive *have* is a main verb, and stays downstairs (i.e., has affix lowering applied)?

- c) I have had a horrible day.  
 d) I have never had a pencil case like that!  
 e) Have you seen my backpack?  
 f) \*Have you a pencil?

*Part 2:* Consider now the following sentence, which is grammatical in some varieties of British English:

- g) Have you a pencil?

Does the possessive verb *have* in these dialects undergo  $V \rightarrow T$  movement? How can you tell?

### 7. HEBREW CONSTRUCT STATE ( $N \rightarrow D$ )

[Data Analysis; Intermediate]

*Background:* In the text above we considered two variations on head movement:  $V \rightarrow T$ , and  $T \rightarrow C$ . In an influential article in 1988, Ritter proposed that head movement might also apply inside DPs. More particularly she proposed that in many Semitic languages there is a rule of  $N \rightarrow D$  movement. This applies in a possessive construction called the construct state. (Based on the analysis of Ritter 1988, data from Borer 1999.)

- a) *beit ha-more*  
 house the-teacher  
 "the teacher's house"

In the construct state, the noun takes on a special form (the construct):

- b) *Free form* bayit “house”  
     *Construct* beit “house”

Ritter proposes that the construct arises when the noun moves into the determiner. The construct morphology indicates that this noun is attached to the determiner. A tree for sentence (a) is given below. The possessor noun sits in the specifier of the NP, the possessed N head undergoes head movement to D, where it takes on the construct morphology:

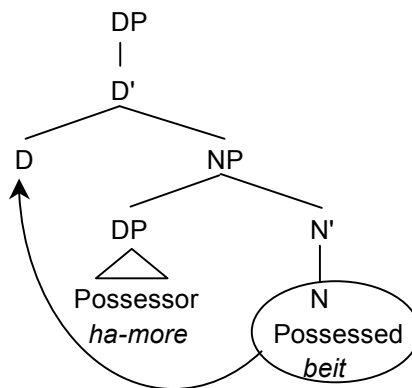

This results in the surface DP [*beit ha-more*].

*Part 1:* Consider now the following evidence, how does this support Ritter’s N → D analysis?

- c) \*ha-beit ha-more  
     the house the teacher  
     “the house of the teacher”

*Part 2:* Now look at the positioning of adjectives. How does this support Ritter’s analysis? Note in particular what noun the adjective modifies. (If you are having trouble with this question, trying drawing the tree of what the whole DP would look like before N → D movement applied.) M stands for “masculine”, and F stands for feminine:

- d) more           kita       xadaS  
     teacher-M   class-F   new-M  
     “a class’s new teacher” or “the new teacher of a class”  
     but:        “\*a new class’s teacher” or “\*the teacher of a new class”

**8. ENGLISH<sup>5</sup>***[Data Analysis; Intermediate]*

Consider the italicized noun phrases in the following sentences:

- I ate *something spicy*.
- Someone tall* was looking for you.
- I don't like *anyone smart*.
- I will read *anything interesting*.

One analysis that has been proposed for noun phrases like the ones above involves generating elements like *some* and *any* as determiners, and generating elements *one* and *thing* as nouns (under N), and then doing head-to-head movement of the Ns up to D. The tree below illustrates this analysis:

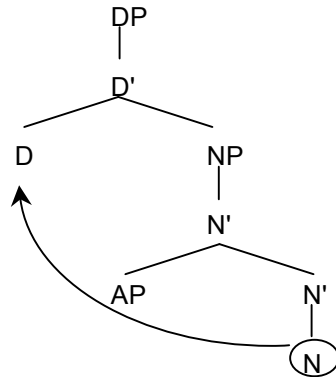

Give an argument in favor of this analysis, based on the order of elements within the noun phrase in general, and the order of elements in the noun phrases above.

**9. ENGLISH TREES***[Application of Skills; Basic to Advanced]*

Draw trees for the following English sentences; be sure to indicate all transformations with arrows.

- I have always loved peanut butter.
- I do not love peanut butter.
- Martha often thinks Kim hates phonology.
- Do you like peanut butter?
- Have you always hated peanut butter?

---

<sup>5</sup> Thanks to Jila Ghomeshi for contributing this problem set.

- f) Are you always so obtuse? (*Assume that AdjP can be a complement to T if it is a predicate, as in this case*)
- g) Will you bring your spouse?
- h) Has the food been eaten?
- i) Mike is always eating peanuts.

### CHALLENGE PROBLEM SETS

#### CHALLENGE PROBLEM SET 1: FLOATING QUANTIFIERS

[Critical Thinking; Challenge]

In English, quantifiers normally appear before a DP. Up to this point in the book, we've been treating them as determiners. However, certain quantifiers can appear before determiners. One example is the quantifier *all*: *all the men*. In section 4 above, we argued that we can have stacked VPs. Let's extend that analysis and claim that we can have stacked DPs in certain circumstances (limited by the particular determiners involved). The structure of *all the men* is given below:

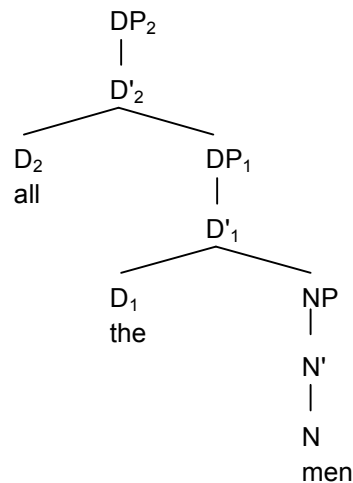

There are two DPs here (DP<sub>1</sub> and DP<sub>2</sub>), in principle either of them could be moved to the specifier of TP. With this in mind provide an argument using the following data to argue that subjects in English start in the specifier of VP:

- a) All the men have gone.
- b) The men have all gone.

**CHALLENGE PROBLEM SET 2: VERB MOVEMENT<sup>6</sup>***[Data Analysis; Challenge]*

Based on the following data, do German and Persian exhibit  $V \rightarrow T$  movement? Explain how you came to your answer.

*German*

- a) Sprechen Sie Deutsch?  
speak you German  
“Do you speak German?”
- b) Ist er nach Hause gegangen?  
is he to home gone  
“Has he gone home?”
- c) Er sitzt nicht auf diesem Tisch.  
he sits not on this table  
“He does not sit on this table.”
- d) Sie soll nicht auf diesem Tisch sitzen.  
she must not on this table sit  
“She must not sit on this table.”

*Persian*

- a) Rafti to madrese?  
went you school  
“Did you go to school?”
- b) Bâyad un biyâd?  
must he come  
“Must he come?”
- c) Man keyk na-poxtam.  
I cake not-cooked  
“I did not bake cakes.”
- d) Un na-xâhad âmad.  
he not-will come  
“He will not come.”

---

<sup>6</sup> Thanks to Simin Karimi for contributing this data.

**CHALLENGE PROBLEM SET 3: GERMANIC VERB SECOND***[Data Analysis and Critical Thinking; Challenge]*

*Background:* Many of the languages of the Germanic language family exhibit what is known as **verb second** order (also known as V2). With V2, the main restriction on word order is that, in main clauses, the constituents may appear in essentially any order, as long as the verb is in the second position in the sentence. This is seen in the following data from German:

*German* (Vikner 1995)

- a) Die Kinder haben diesen Film gesehen.  
 the children have this film seen  
 “The children have seen this film.”
- b) Diesen Film haben die Kinder gesehen.

One analysis of this phenomenon uses the specifier of CP as a “topic” position. The most topical constituent (the bit under discussion) is put in the specifier of CP (i.e., is moved there – we’ll discuss this kind of movement in chapter 12). Whatever is in T then moves to the C head by T → C movement:

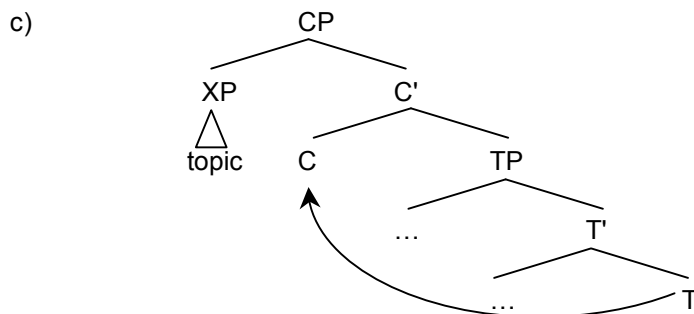

This puts T in second position. For the tree above and this problem set, assume that the VP and the TP have their heads on the right, but CP is left headed.

*Part 1:* Now consider the following data from embedded clauses in German.

- d) Er sagt [daß die Kinder diesen Film gesehen haben].  
 He said that the children this film saw have  
 “He said that the children saw this film.”
- e) \*Er sagt [daß die Kinder haben diesen Film gesehen].

How does this data support the T → C analysis of V2? (Having trouble? Think about embedded *yes/no* questions in English.)

*Part 2:* Consider now the following sentence of German and compare it to the embedded clauses in part 1 above.

- f) Gestern sahen die Kinder den Film.  
 Yesterday saw the children the film  
 “The children saw the film yesterday.”

Given what you now know about V2 and T → C movement in these languages, is German a V → T raising language or an affix lowering language?

*Bonus:* Is the data in part 1 above consistent with your answer? If not how might you make it consistent?

**CHALLENGE PROBLEM SET 4: PROPER NAMES AND PRONOUNS**

[Data Analysis; Challenge]

Consider the following data from English:

- a) Lucy
- b) \*The Lucy
- c) \*Smiths
- d) The Smiths
- e) Him
- f) \*The him
- g) We linguists love a good debate over grammar.

*Part 1:* One possible analysis of proper names in English is that they involve head movement from an N position into a D position. How does the data in (a–d) above support this idea?

*Part 2:* Consider now the pronouns in (e–g). What category are they? N or D? Is there any evidence for movement?

**CHALLENGE PROBLEM SET 5: ITALIAN N → D<sup>7</sup>**

[Data Analysis and Critical Thinking; Challenge]

(You may want to do Challenge Question 4 before attempting this problem.)

In English, proper names cannot co-occur with determiners (e.g. *\*the John*). However, in Italian proper names of human beings *can* occur with determiners as the following example shows. (The presence or absence of the determiner seems to be free or perhaps stylistically governed.)

---

<sup>7</sup> Jila Ghomeshi contributed this problem set based on data from Longobardi (1994).

- a) i) Gianni mi ha telefonato.  
Gianni me has telephoned  
"Gianni called me up."
- ii) Il Gianni mi ha telefonato.  
the Gianni me has telephoned  
"Gianni called me up."

Now, it has been argued that in the cases where the determiner does *not* occur, the proper name has moved from N to D. Provide an argument to support this view, based on the following examples. (Note: for the purposes of this question treat possessive pronouns such as *my* as adjectives.)

- b) i) Il mio Gianni ha finalmente telefonato.  
the my Gianni has finally telephoned
- ii) \*Mio Gianni ha finalmente telefonato.  
my Gianni has finally telephoned
- iii) Gianni mio ha finalmente telefonato.  
Gianni my has finally telephoned
- c) i) E'venuto il vecchio Cameresi.  
came the older Cameresi
- ii) \*E'venuto vecchio Cameresi.  
came older Cameresi
- iii) E'venuto Cameresi vecchio.  
came Cameresi older
- d) i) L' antica Roma  
the ancient Rome  
"Ancient Rome"
- ii) \*Antica Roma  
ancient Rome
- iii) Roma antica  
Rome ancien

